

Securefast

Installation Instructions for SBL330S Push Button Lock with Knob Handle

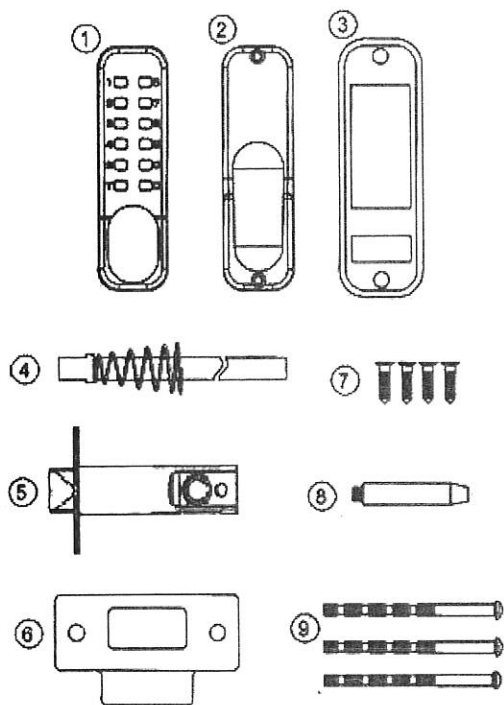

LIST OF PARTS

- 1) Digital Lock with Knob Handle
- 2) Internal Block
- 3) Neoprene Seals x 2
- 4) Spindle with spring
- 5) Latch (60mm standard)
- 6) Striker Plate
- 7) Wood screws x 4 (For securing Latch and Striker Plate)
- 8) Bolt Guide
- 9) Fixing Bolts x 3 (1 spare)

BEFORE INSTALLATION PLEASE:

- 1) Ensure all parts work properly
- 2) Choose and set a code following the "Setting/Changing the Code" instructions. All or part of the push-buttons can be chosen in no particular order. Codes with 4 digits provide maximum security
- 3) Ensure that both knob handles of the Digital Lock can be moved freely. Check that the Hold Back function can be engaged and keeps the latch retracted and handle pressed. Also check that the latch moves freely by pressing the end and by turning with the spindle

All code on

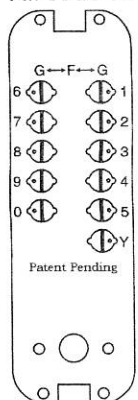

All code off

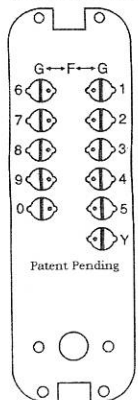

Setting/Changing the Code

On the reverse of the Digital Lock Unit you will see slotted buttons which correspond to the push buttons on the front of the Lock.

To set a button to operate within the code turn the slotted button relating to the number so that the dot is facing outwards (towards the 'G').

To take a button out the code turn the slotted button so the dot is facing inward (towards the 'F').

Check the code on the Lock functions before fitting to the door.

Installation

Applying the Template

Correctly position and tape the template, to either the internal or external door face, at the desired height from the floor level. Ensure that the relevant, marked, door edge on template is correctly aligned with actual door edge. (Figure 1)

Mark the six 10mm diameter holes for the spindle of the Digital Lock and for the bolt through fixings.

Drill all marked holes.

Using a wood chisel remove the excess material from between the four 10mm holes to produce a clear rectangular slot.

Door edge

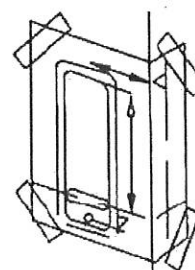

Figure 1

Securefašt

Installing the Latch

Mark a central point on the 'centre line of latch' across the thickness of the door. (Figure 2)
At the marked position drill a 25mm diameter hole x 80mm deep.
Inset Latch into the hole and draw around the face plate.
Remove latch and cut a 3mm rebate to allow the Latch face plate to sit flush in the door.
Secure latch with wood fixing screws ensuring the positioning is square.

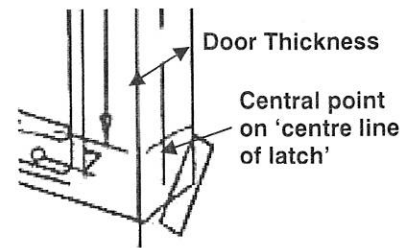

Figure 2

Installation of Reinforcement Pin

Screw the Bolt Guide in to Hole A for a door opening to the right (clockwise opening). (Figure 3)
Screw the Bolt Guide in to Hole B for a door opening to the left (anti-clockwise opening). (Figure 3)
The guide will locate in Hole 'O' of the latch to help maintain positioning. (Figure 3b)

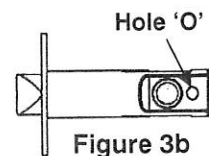
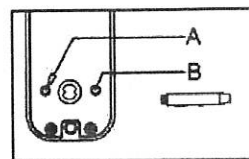

Figure 3

Positioning of Spindle

The spindle is designed for doors 35 to 65 mm thick. Therefore shorten, if necessary, to suit door thickness.
When inserting the spindle locate the end with the spring fitted into the Lever Handle Digital Lock on the external door face and the other end into the internal side.

Fixing the Lock

IMPORTANT: Do not close the door before confirming that the code and lock is functioning correctly.

If necessary, shorten the fixing bolts in order to suit the thickness of the door.
When shortening the fixing bolts allow at least 4/5 threads to screw into the lock case.
Locate the rubber seal behind the Digital Lock and using the fixing bolts secure the top and bottom of the Lock to the door.
Before final tightening ensure the Lock is vertical and test mechanism to ensure that it is moving freely.
Do not excessively tighten the Lock and seals to the door as it could damage the operation of the mechanism.

Fixing Striker Plate

IMPORTANT: The striker must be positioned so that only the latch itself can enter the aperture but the anti-thrust must stop on the striker plate itself to maintain its anti-burglar function when the door is locked.

Correctly position the striker plate, taking the above into consideration.
Once the correct position is determined, draw around the striker plate and mark the two holes.
Remove the striker and cut a 1mm rebate to allow the striker to sit flush within the door frame.
If necessary drill or cut a recess, at the correct position of the striker, for the Latch to enter when the door is closed.

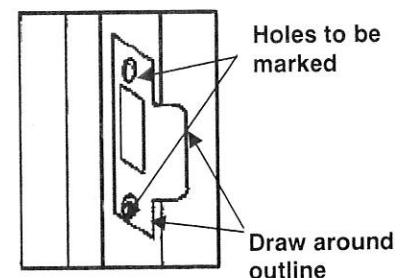

Securefast

Drill the two, marked, holes for securing striker.
Fix the striker with one screw first. Test the Lock to see if it works and is latching and locking correctly. If not proceed with any necessary adjustments before securing completely.
If no adjustments are to be made completely secure striker with second screw.

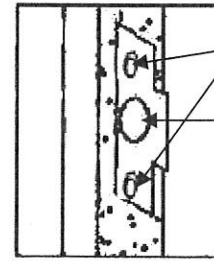

Drill Pilot
Holes
Cut out or
drill a recess.

Securefast plc

Unit 6, The Cedars Business Centre, Avon Road, Cannock, Staffs, England, WS11 1QJ

Tel +44 (0) 1543 501600

Fax +44 (0) 1543 501601

www.securefast.co.uk