



ARHT-E, ARHT

Rod End Bearings - Self-Lubricating
3 Piece, Heavy Duty, Male & Female



Plating: When specified in materials block, body Cadmium plated all surfaces per AMS-QQ-P-416, Type I, Class 2.

Dimensions: Dimensions apply after plating.

- Option:
- For left hand threads add "L" to prefix. Examples: ARHTL4E or ARHTL4.
 - For keyway or keyslot options, add suffix "W" to part number.
 - For "J" from threads per AS8879, add suffix "J" to part number. Examples: ARHT10EJW or ARHT10JW.
 - To specify CRES 17-4PH race material, add suffix "H" to designation. Examples: ARHT8ECRH or ARHT8CRH.

Notes: UNF-3A = Male, UNF-3B = Female

MATERIALS

Part No.	Ball	Race	Liner	Body
Basic No.	CRES 440C, 55-62 HRC	CRES 410 Heat Treated	*Teflon/Fabric Permanently Bonded to race I.D.	C.M. STL, Heat Treated Cad. Plated
No. + CR	CRES 440C 55-62 HRC	CRES 410 Heat Treated	*Teflon/Fabric Permanently Bonded to race I.D.	CRES 17-4PH, Heat Treated

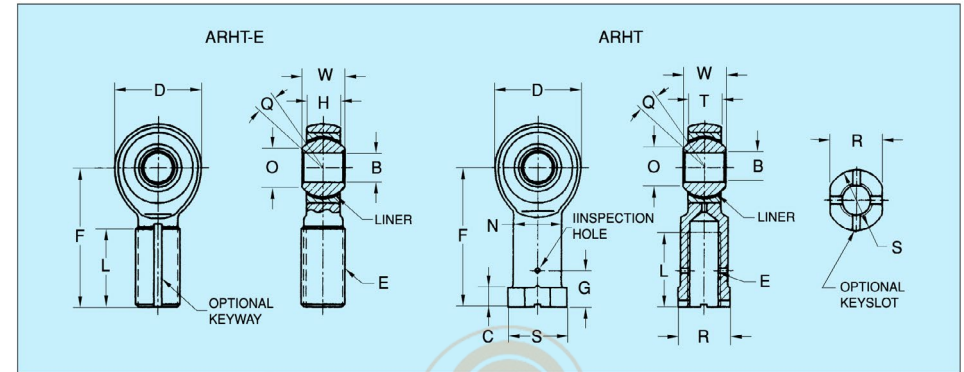

NMB Part Number	(B) Bore Diameter		(D) Head Diameter		(W) Ball Width		(H) Body Width		(O) Ball Diameter		(F) Shoulder Diameter		(E) Ball C/L to End		(Q) Thread Size		(L) Misalign-ment		(L) Thread Length		(L) Thread Depth		(G) Drill C/L To End		(N) Shank Diameter		(S) Flange Diameter		(C) Flange Thickness		(R) Wrench Flat		No Load Rotational Breakaway Torque		Ultimate Static Radial Load		Axial Static Proof Load		Approx. Weight		
	Inch	mm	Inch	mm	Inch	mm	Inch	mm	Inch	mm	Inch	mm	Inch	mm	Inch	mm	Inch	mm	Inch	mm	Inch	mm	Inch	mm	Inch	mm	Inch	mm	Inch	mm	Inch	mm	In-lb	N-m	lbs	N	lbs	N	lbs	N	lbs
ARHT4E ARHT4	-.0000 +.0000	0.0000	+.010 -.010	0.254	+.000 -.002	0.000	+.005 -.005	0.13 -0.13	Ref.	Ref.	Ref.	Ref.	+.010 -.010	0.254 -0.254	UNF-3A UNF-3B	Ref.	Ref.	Ref.	Ref.	+.010 -.010	0.254 -0.254	Ref.	Ref.	Ref.	Ref.	+.010 -.062	0.254 -1.57	+.002 -.010	0.05 -0.25	5-6	0.06-0.68	7550	33562	1000	4448	.067 .084	0.030 0.038				
ARHT5E ARHT5	.3125 7.938	.900	22.86	.437	11.10	.327	8.31	.593	15.06	.401	10.18	1.875	47.62	1.625	41.28	1/8-24	14°	1.187	30.15	.875	22.22	.437	11.10	.547	13.89	.625	15.88	250	6.35	.562	14.27	1-10	0.11-1.13	9200	40922	1100	4893	.095 .102	0.043 0.046		
ARHT6E ARHT6	.3750 9.525	1.025	26.04	.500	12.70	.416	10.57	.687	17.45	.471	11.96	1.938	49.23	1.812	46.02	7/16-20	9°	1.187	30.15	1.000	25.40	.500	12.70	.610	15.49	.687	17.45	250	6.35	.625	15.88	1-10	0.11-1.13	10900	48483	1660	7384	.140 .160	0.064 0.073		
ARHT7E ARHT7	.4375 11.112	1.150	29.21	.562	14.27	.452	11.48	.781	19.84	.542	13.77	2.125	53.98	2.000	50.80	1/2-20	10°	1.281	32.54	1.125	28.58	.562	14.27	.735	18.67	.875	22.22	250	6.35	.750	19.05	1-10	0.11-1.13	14050	62494	1850	8229	.210 .230	0.095 0.104		
ARHT8E ARHT8	.5000 12.700	1.337	33.96	.625	15.88	.515	13.08	.875	22.22	.612	15.54	2.438	61.93	2.250	57.15	3/8-18	9°	1.468	37.29	1.250	31.75	.687	17.45	.860	21.84	1.000	25.40	250	6.35	.875	22.22	1-10	0.11-1.13	23400	104083	2040	9074	.330 .340	0.150 0.154		
ARHT10E ARHT10	.6250 15.875	1.525	38.74	.750	19.05	.577	14.66	1.062	26.97	.752	19.10	2.625	66.68	2.500	63.50	1/2-16	12°	1.562	39.67	1.375	34.92	.812	20.62	.985	25.02	1.125	28.58	375	9.52	1.000	25.40	1-10	0.11-1.13	26050	115870	2430	10809	.480 .490	0.218 0.222		
ARHT12E ARHT12	.7500 19.050	1.775	45.08	.875	22.22	.640	16.26	1.250	31.75	.892	22.66	2.875	73.02	2.875	73.02	3/4-14	13°	1.687	42.85	1.625	41.28	.937	23.80	1.110	28.19	1.250	31.75	375	9.52	1.125	28.58	1-10	0.11-1.13	34500	153456	2810	12499	.730 .740	0.331 0.336		

* A trade name of E.I. duPont de Nemours & Co., Inc.