

Eurocell Profiles Ltd

Fairbrook House
Clover Nook Road
Alfreton
Derbyshire DE55 4RF
Tel: 01773 842100 Fax: 01773 842199
e-mail: info@eurocell.co.uk
website: www.eurocell.co.uk



Agrément Certificate
01/3784
Product Sheet 1

EUROCELL CLADDING SYSTEMS

EUROCELL 125 SHIPLAP CLADDING

This Agrément Certificate Product Sheet⁽¹⁾ relates to Eurocell 125 Shiplap Cladding, PVC-UE cladding planks for use as protective/decorative cladding over external brick or block masonry walls and timber stud walls (with or without sheathing) of new and existing domestic and non-domestic buildings up to 18 m in height.

(1) Hereinafter referred to as 'Certificate'.

CERTIFICATION INCLUDES:

- factors relating to compliance with Building Regulations where applicable
- factors relating to additional non-regulatory information where applicable
- independently verified technical specification
- assessment criteria and technical investigations
- design considerations
- installation guidance
- regular surveillance of production
- formal three-yearly review.

KEY FACTORS ASSESSED

Strength and stability — the system can withstand dynamic wind pressures not exceeding 1750 Pa (see section 6).

Performance in relation to fire — the system achieved a reaction to fire classification* of D-s3, d2/(AVM) to BS EN 13501-1 : 2007. The use of the cladding is restricted in some cases (see section 7).

Durability — the system will remain effective as a cladding system for a period in excess of 35 years, with only minor changes in surface appearance (see section 11).



The BBA has awarded this Certificate to the company named above for the system described herein. This system has been assessed by the BBA as being fit for its intended use provided it is installed, used and maintained as set out in this Certificate.

On behalf of the British Board of Agrément

Claire Curtis-Thomas

Date of Second issue: 14 March 2019

John Albon — Head of Approvals

Claire Curtis-Thomas

Originally certificated on 18 January 2001

Construction Products

Chief Executive

The BBA is a UKAS accredited certification body – Number 113.

The schedule of the current scope of accreditation for product certification is available in pdf format via the UKAS link on the BBA website at www.bbacerts.co.uk

Readers are advised to check the validity and latest issue number of this Agrément Certificate by either referring to the BBA website or contacting the BBA direct.

Any photographs are for illustrative purposes only, do not constitute advice and should not be relied upon.

British Board of Agrément

Bucknalls Lane
Watford
Herts WD25 9BA

©2019

tel: 01923 665300
clientservices@bbacerts.co.uk
www.bbacerts.co.uk

15 Tests

Tests were carried out on the planks to determine:

- voidage
- thickness of layers
- density
- overall thickness
- impact resistance of unaged and UV aged material
- appearance after UV ageing
- simulated wind-load bending
- impact resistance (cladding panel)
- flexural strength and modulus of elasticity
- hard body impact.

16 Investigations

16.1 Permissible dynamic wind pressures were calculated from the simulated wind-load bending test and nail withdrawal data.

16.2 An examination was made of data relating to:

- reaction to fire
- colour stability.

16.3 The manufacturing process was evaluated, including the methods adopted for quality control, and details were obtained of the quality and composition of the materials used.

16.4 The practicability of installation was assessed.

Bibliography

BRE Report 443 BR 443 : 2006 *Conventions for U value calculations*

BS 5250 : 2011 + A1 : 2016 *Code of practice for control of condensation in buildings*

BS EN 1991-1-4 : 2005 + A1 : 2010 *Eurocode 1 — Actions on structures — General actions — Wind actions*

NA to BS EN 1991-1-4 : 2005 + A1 : 2010 UK National Annex to *Eurocode 1 — Actions on structures — General actions — Wind actions*

NA to BS EN 1995-1-1 : 2004 + A1 : 2008 UK National Annex to *Eurocode 5 — Design of timber structures — General — Common rules and rules for buildings*

BS EN 1996-1-1 : 2005 + A1 : 2012 *Eurocode 6 — Design of masonry structures — General rules for reinforced and unreinforced masonry structures*

NA to BS EN 1996-1-1 : 2005 + A1 : 2012 UK National Annex to *Eurocode 6 — Design of masonry structures*

— *General rules for reinforced and unreinforced masonry structures* BS EN 1996-3 : 2006 *Eurocode 6 — Design of masonry structures — Simplified calculation methods for unreinforced masonry structures*

BS EN 1996-3 : 2006 *Eurocode 6 — Design of masonry structures — Simplified calculation methods for unreinforced masonry structures*

NA + A1 : 2014 to BS EN 1996-3 : 2006 UK National Annex to *Eurocode 6 — Design of masonry structures — Simplified calculation methods for unreinforced masonry structures*

BS EN 13245-2 : 2008 *Plastics — Unplasticized poly(vinyl chloride) (PVC-U) profiles for building applications — PVC-U profiles and PVC-UE profiles for internal and external wall and ceiling finishes*

BS EN 13501-1 : 2007 + A1 : 2009 *Fire classification of construction products and building elements — Classification using data from reaction to fire tests*

BS EN ISO 6946 : 2017 *Building components and building elements — Thermal resistance and thermal transmittance — Calculation methods* BS EN ISO 9001 : 2008 *Quality management systems — Requirements*

BS EN ISO 9001 : 2008 *Quality management systems — Requirements*

BS EN ISO 14001 : 2004 *Environmental management systems — Requirements with guidance for use*

Figure 2 Trims

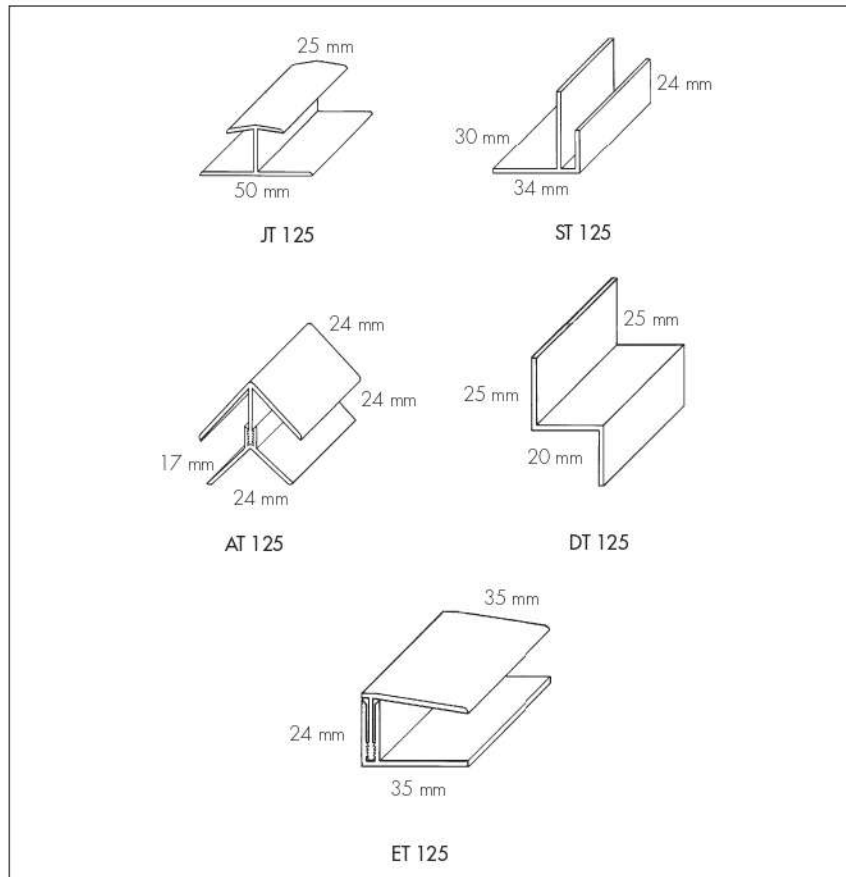

1.2 The interlocking planks' characteristics are given in Table 1. The planks are composed of a cellular calcium/zinc PVC-U core beneath a rigid outer weathering impact-modified calcium/zinc PVC-U skin.

Table 1 Characteristics

Characteristic (unit)	Nominal value
Standard length (m)	5
Cover width (mm)	125
Thickness (mm)	6
Thickness of rigid outer surface (mm)	0.5
Nominal weight ($\text{kg}\cdot\text{m}^{-1}$)	0.64
Average density ($\text{kg}\cdot\text{m}^{-3}$)	490

1.3 The trims consist of extrusions and injection mouldings of impact-modified PVC-U.

2 Manufacture

2.1 The planks are manufactured by co-extruding a high-impact calcium/zinc PVC-U compound (see section 1.2) onto a foam calcium/zinc PVC-UE core compound, and cooling and forming to section. Cellular PVC-U (PVC-UE) is formed in the process by the evolution of gas from sodium bicarbonate. A clear, protective polyethylene film is applied to the outer face of the extrusion before the plank is cut to length.

2.2 The trims are manufactured by conventional extrusion and injection-moulding techniques.

2.3 As part of the assessment and ongoing surveillance of product quality, the BBA has:

- agreed with the manufacturer the quality control procedures and product testing to be undertaken
- assessed and agreed the quality control operated over batches of incoming materials
- monitored the production process and verified that it is in accordance with the documented process
- evaluated the process for management of nonconformities
- checked that equipment has been properly tested and calibrated
- undertaken to carry out the above measures on a regular basis through a surveillance process, to verify that the specifications and quality control operated by the manufacturer are being maintained.

Information in this Certificate may assist the client, designer (including Principal Designer) and contractor (including Principal Contractor) to address their obligations under these Regulations.

See sections: 3 *Delivery and site handling* (3.3) and 13 *General* (13.6) of this Certificate.

Additional Information

NHBC Standards 2019

In the opinion of the BBA, Eurocell 125 Shiplap Cladding, if installed, used and maintained in accordance with this Certificate, can satisfy or contribute to satisfying the relevant requirements in relation to *NHBC Standards*, Chapters 6.1 *External Masonry Walls* (section 6.1.16 – *Cladding*) and 6.2 *External timber framed walls*.

CE marking

The Certificate holder has taken the responsibility of CE marking the system in association with harmonised European Standard BS EN 13245-2 : 2008. An asterisk (*) appearing in this Certificate indicates that data shown are given in the manufacturer's Declaration of Performance.

Technical Specification

1 Description

1.1 Eurocell 125 Shiplap Cladding comprises protective and decorative white cellular PVC-U cladding planks with matching PVC-U trims (see Figures 1 and 2).

Figure 1 Eurocell 125 Shiplap Cladding

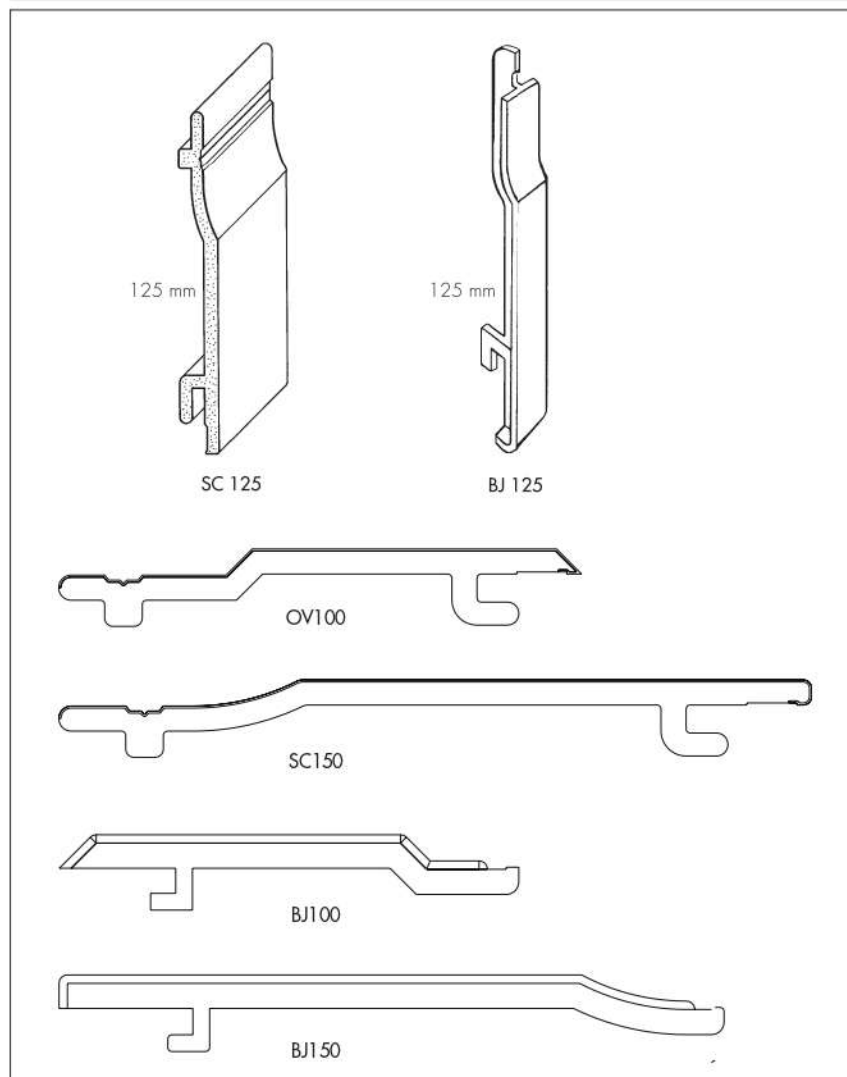

17 Conditions

17.1 This Certificate:

- relates only to the product/system that is named and described on the front page
- is issued only to the company, firm, organisation or person named on the front page — no other company, firm, organisation or person may hold or claim that this Certificate has been issued to them
- is valid only within the UK
- has to be read, considered and used as a whole document — it may be misleading and will be incomplete to be selective
- is copyright of the BBA
- is subject to English Law.

17.2 Publications, documents, specifications, legislation, regulations, standards and the like referenced in this Certificate are those that were current and/or deemed relevant by the BBA at the date of issue or reissue of this Certificate.

17.3 This Certificate will remain valid for an unlimited period provided that the product/system and its manufacture and/or fabrication, including all related and relevant parts and processes thereof:

- are maintained at or above the levels which have been assessed and found to be satisfactory by the BBA
- continue to be checked as and when deemed appropriate by the BBA under arrangements that it will determine
- are reviewed by the BBA as and when it considers appropriate.

17.4 The BBA has used due skill, care and diligence in preparing this Certificate, but no warranty is provided.

17.5 In issuing this Certificate, the BBA is not responsible and is excluded from any liability to any company, firm, organisation or person, for any matters arising directly or indirectly from:

- the presence or absence of any patent, intellectual property or similar rights subsisting in the product/system or any other product/system
- the right of the Certificate holder to manufacture, supply, install, maintain or market the product/system
- actual installations of the product/system, including their nature, design, methods, performance, workmanship and maintenance
- any works and constructions in which the product/system is installed, including their nature, design, methods, performance, workmanship and maintenance
- any loss or damage, including personal injury, howsoever caused by the product/system, including its manufacture, supply, installation, use, maintenance and removal
- any claims by the manufacturer relating to CE marking.

17.6 Any information relating to the manufacture, supply, installation, use, maintenance and removal of this product/system which is contained or referred to in this Certificate is the minimum required to be met when the product/system is manufactured, supplied, installed, used, maintained and removed. It does not purport in any way to restate the requirements of the Health and Safety at Work etc. Act 1974, or of any other statutory, common law or other duty which may exist at the date of issue or reissue of this Certificate; nor is conformity with such information to be taken as satisfying the requirements of the 1974 Act or of any statutory, common law or other duty of care.

2.4 The management system of Eurocell Profiles Ltd has been assessed and registered as meeting the requirements of BS EN ISO 9001 : 2008 and BS EN ISO 14001 : 2004 by BSI (Certificates FM 45551 and 25110/A/0001/UK/En respectively).

3 Delivery and site handling

3.1 Standard 5 m lengths of the extrusions are delivered to site sealed in polyethylene sleeves. Pack quantities vary according to profile size.

3.2 All cladding packs bear the Certificate holder's product code.

3.3 Unloading should be carried out by hand to avoid damage to the components and they should be stored flat in their protective wrapping on a clean, level surface. Stacks must not exceed one-metre in height and should be restrained to prevent collapse. To avoid damage, it is recommended that additional protection be provided when the planks are stored in the open.

3.4. Care must be taken to avoid contact with solvents or materials containing volatile organic components.

Assessment and Technical Investigations

The following is a summary of the assessment and technical investigations carried out on Eurocell 125 Shiplap Cladding.

Design Considerations

4 General

4.1 Eurocell 125 Shiplap Cladding is suitable for horizontal, vertical and diagonal fixing as a decorative and protective external facing over timber frame or masonry wall constructions of new and existing buildings.

4.2 The system is restricted for use in buildings up to 18 m.

4.3 The wall and the sub-frame to which the cladding is fixed should be structurally sound and constructed in accordance with the requirements of the relevant national Building Regulations and Standards.

4.4 Brickwork or blockwork walls should be constructed in the conventional manner in accordance with the national Building Regulations and BS EN 1996-1-1 : 2005 and BS EN 1996-3 : 2006 and their UK National Annexes.

4.5 Timber stud walls should be designed and constructed in accordance with the UK National Annex to BS EN 1995-1-1 : 2004. Studding and framing should be adequately supported by noggins to ensure rigidity.

4.6 When used over a sheathed timber stud frame or a masonry substrate, the cladding should be fixed to preservative-treated, good-quality timber battens (measuring not less than 25 by 38 mm) rigidly fixed to the studding (not the supported sheathing) or masonry substrate at 600 mm centres or closer.

4.7 PVC-UE has a similar coefficient of thermal expansion to that of conventional rigid PVC-U. To avoid distortion in service, care should be taken not to install the cladding in extremes of temperature (ie below 5°C or above 25°C), and to allow adequate gaps for expansion (see the relevant sections of the *Installation* part of this Certificate).

4.8 To comply with the NHBC requirement (see *NHBC Standards 2019*, Chapter 6.9.18), a minimum 38 mm drained and vented cavity behind the cladding is required.

5 Practicability of installation

The system is designed to be installed by a competent general builder, or a contractor, experienced with this type of system.

6 Strength and stability

Wind loading



6.1 Under wind loading, the most likely mode of failure of the cladding will be by nail withdrawal under wind suction. Wind loads should be calculated in accordance with BS EN 1991-1-4 : 2005 and its UK National Annex.

6.2 When installed in accordance with the requirements of this Certificate, onto battens at 600 mm spacings, the cladding can withstand dynamic wind pressures up to 1750 Pa.

6.3 The permissible dynamic wind pressure may be increased by reducing batten spacing. This is particularly recommended at the corners of buildings and in exposed locations. In common with all cladding, the adequacy of a proposed installation should always be checked by a suitably qualified and experienced individual, who should check the adequacy of the fixing of battens to the substrate, which is not covered by this Certificate.

6.4 When designing a timber stud wall to resist racking forces, the cladding should not be taken into account.

Regulations

In the opinion of the BBA, Eurocell 125 Shiplap Cladding, if installed, used and maintained in accordance with this Certificate, can satisfy or contribute to satisfying the relevant requirements of the following Building Regulations (the presence of a UK map indicates that the subject is related to the Building Regulations in the region or regions of the UK depicted):



The Building Regulations 2010 (England and Wales) (as amended)

Requirement: A1	Loading
Comment:	The system is acceptable for use as set out in section 6 of this Certificate.
Requirement: B4(1)	External fire spread
Requirement: B3(2)(4)	Internal fire spread (structure)
Comment:	The system achieved a reaction to fire classification of Ds3, d2/AHM and its use is restricted under this Requirement. See sections 7.1, 7.2 and 7.4 of this Certificate.
Requirement: C2(b)(c)	Resistance to moisture
Comment:	The system does not form a watertight or airtight facing. To achieve a waterproof barrier on exposed surfaces, a breather membrane must be provided. See section 8 of this Certificate.
Regulation: 7	Materials and workmanship (applicable to Wales only)
Regulation: 7(1)	Materials and workmanship (applicable to England only)
Comment:	The system is acceptable. See section 11.1 and the <i>Installation</i> part of this Certificate.
Regulation: 7(2)	Materials and workmanship (applicable to England only)
Comment:	The cladding is restricted by this Regulation. See sections 7.1 and 7.2 of this Certificate.



The Building (Scotland) Regulations 2004 (as amended)

Regulation: 8(1)(2)	Durability, workmanship and fitness of materials
Comment:	The system is acceptable. See sections 10 and 11.1 and the <i>Installation</i> part of this Certificate.
Regulation: 9	Building standards applicable to construction
Standard: 1.1(a)(b)	Structure
Comment:	The system can contribute to satisfying this Standard, with reference to clause 1.1.1 ⁽¹⁾⁽²⁾ , as set out in section 6 of this Certificate.
Standard: 2.4	Cavities
Standard: 2.6	Spread to neighbouring buildings
Standard: 2.7	Spread on external walls
Comment:	The system is restricted by these Standards, with reference to clauses 2.4.2 ⁽¹⁾⁽²⁾ , 2.4.4 ⁽¹⁾ , 2.4.7 ⁽¹⁾ , 2.4.9 ⁽²⁾ , 2.6.2 ⁽¹⁾⁽²⁾ , 2.6.4 ⁽¹⁾⁽²⁾ and 2.7.1 ⁽¹⁾⁽²⁾ , as set out in sections 7.1, 7.3 and 7.4 of this Certificate.
Standard: 3.10	Precipitation
Comment:	The system does not form a watertight or airtight facing. To achieve a waterproof barrier on exposed substrates, a breather membrane must be provided. See section 8 of this Certificate.
Standard: 3.15	Condensation
Comment:	Provided there is provision for adequate drainage and ventilation behind the cladding, and a breather membrane is incorporated as required, the system can contribute to satisfying this Standard, with reference to clauses 3.15.4 ⁽¹⁾ and 3.15.5 ⁽¹⁾ . See section 8 of this Certificate.
Regulation: 12	Building standards applicable to conversions
Comment:	All comments in relation to the system under Regulation 9, Standards 1 to 6, also apply to this Regulation, with reference to clause 0.12.1 ⁽¹⁾⁽²⁾ and Schedule 6 ⁽¹⁾⁽²⁾ . (1) Technical Handbook (Domestic). (2) Technical Handbook (Non-Domestic).



The Building Regulations (Northern Ireland) 2012 (as amended)

Regulation: 23	Fitness of materials and workmanship
Comment:	The system is acceptable. See section 11.1 and the <i>Installation</i> part of this Certificate.
Regulation: 28(b)	Resistance to moisture and weather
Comment:	The system does not form a watertight or airtight facing. To achieve a waterproof barrier on exposed substrates, a breather membrane must be provided. See section 8 of this Certificate.
Regulation: 30	Stability
Comment:	The system is acceptable for use as set out in section 6 of this Certificate.
Regulation: 35(2)(3)	Internal fire spread – structure
Regulation: 36(a)	External fire spread
Comment:	The system achieved a reaction to fire classification of Ds3, d2/AHM and its use is restricted under these Regulations. See sections 7.1, 7.2 and 7.4 of this Certificate.

Figure 3 Installation details

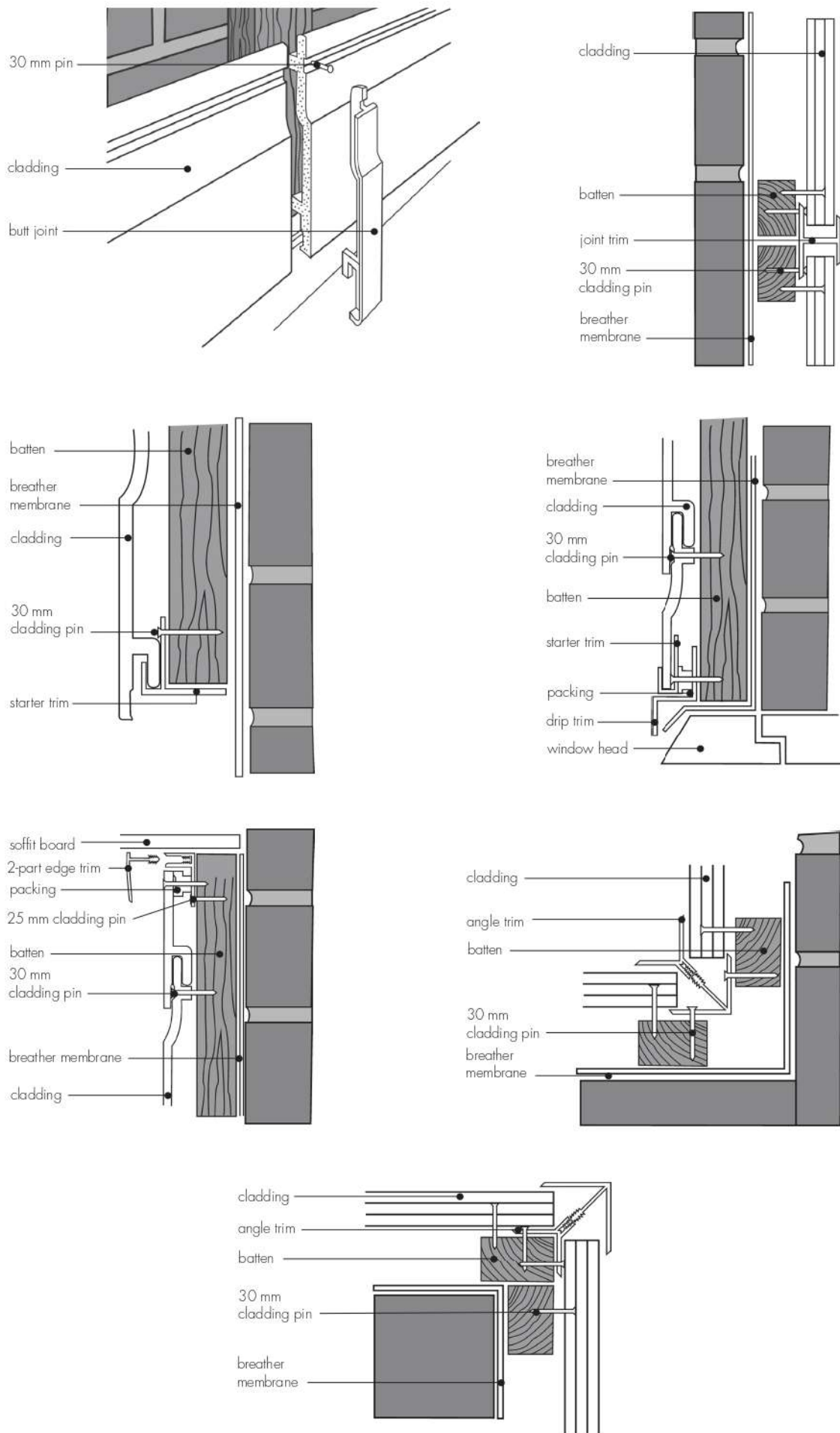

Resistance to impact



6.5 The cladding is not recommended for use at ground-floor level, where severe impacts may occur. It is suitable for use above ground-floor level in locations where it is unlikely to be subjected to impact from thrown or kicked objects.

7 Performance in relation to fire



7.1 The system achieved a reaction to fire classification* of D-s3, d2/AHM to BS EN 13501-1 : 2007.



7.2 The system is not classified as non-combustible and may be used on buildings with no storey 18 m or more above the ground, and 1 m or more from a boundary. With minor exceptions, the system should be included in calculations of unprotected areas.



7.3 The system is not classified as non-combustible ('High Risk' in Scotland) and may be used on buildings with no storey 18 m or more above the ground, and more than 1 m from a boundary. With minor exceptions, the system should be included in calculations of unprotected areas. The system is further restricted on some parts of buildings of some occupancy classes.



7.4 Although the spread-of-flame across the surface of PVC is limited, the material does tend to char and may fall away when exposed to fire. Due consideration should always be given to any combustible materials behind the cladding, which may become exposed in the event of fire. Where necessary, cavity barriers should be incorporated behind the cladding, as required under the relevant national Building Regulations.

8 Air and water penetration



8.1 The cladding is not airtight, watertight or water-vapour-tight. When used on exposed substrates, such as timber stud walls, the system must be backed by a breather membrane acting as a vapour-permeable water barrier, incorporated behind the cladding under the supporting battens. This barrier must satisfy the requirements of BS 5250 : 2011 and have a vapour resistance of less than $0.6 \text{ MN}\cdot\text{s}\cdot\text{g}^{-1}$.

8.2 Where cladding is used as a decorative facing attached to weathertight masonry walls, a vapour permeable water barrier is not necessary as the amount of water that will penetrate the cladding will be small and will not have an adverse effect on the wall.

8.3 If the cladding is used in the renovation of a masonry wall which is structurally sound but not fully weathertight, the use of a vapour-permeable water barrier is advisable.

8.4 Provision must always be made to allow water that has penetrated behind the cladding to drain away.

9 Thermal insulation

For the purpose of U value calculations in accordance with BS EN ISO 6946 : 2017 and BRE Report BR 443 : 2006, the cavity between the system and the wall should be treated as a 'well ventilated' air-layered cavity; the thermal insulating value of the cavity, and everything between it and the external environment, should be taken as equivalent to an internal boundary layer (ie a total of $0.13 \text{ M}^2\cdot\text{K}^{-1}\cdot\text{W}^{-1}$).

10 Maintenance



10.1 The cladding can be washed with water and detergent. Solvent-based cleaners should not be used.

10.2 Replacement of a damaged section can be carried out but may require the temporary removal of undamaged planks above the damaged area.

10.3 Paint must not be applied as it can cause premature embrittlement of PVC-U products and the application of dark colours to PVC-U cladding could lead to a risk of thermal distortion.

11 Durability



11.1 The system will remain effective as cladding for a period in excess of 35 years.

11.2 The cladding will retain its decorative function with only minor changes in surface appearance. However, staining will result from contact with certain materials or substrates (eg creosote or bitumen).

12 Reuse and recyclability

The PVC-U and PVC-UE profile material can be recycled.

13 General

13.1 Flat-headed, stainless steel A4 cladding pins (30 mm long by 2.2 mm shank diameter) are used to fix cladding planks to timber battens (secret fixing) and fixing trims are required. Stainless steel nails (25 mm long) are also used for fixing trims.

13.2 The substrate for the system should be checked to ensure that it is as prescribed in section 4.3.

13.3 On non-weatherproof substrates, a vapour-permeable water barrier must be installed behind the battens and cladding (see sections 8.1 and 8.3).

13.4 Installation should not be carried out in extremes of temperature (between 5 and 25°C is recommended).

13.5 The components are easy to work using normal woodworking tools for cutting, drilling and shaping. Handsaws should have a fine-toothed blade. Hand-held and bench-mounted power tools with a carbide-tipped blade should be run at speeds similar to, or higher than, those normally used with timber.

13.6 When using power tools to cut or shape the product, it is recommended that eye protection and a coarse-particle dust mask is used.

13.7 Expansion gaps of 5 mm should be provided at the ends of each five-metre plank.

13.8 Adequate provision should be made for drainage and ventilation behind the cladding (see sections 4.8 and 8.4).

13.9 Where butt joints are made between planks, the ends of both planks should be fixed to battens.

13.10 Window head and other protrusions should be protected by a suitable weatherproof membrane or flashing.

14 Procedure

The cladding must be installed in accordance with the instructions given in the manufacturer's literature. Typical installation details are shown in Figure 3.