

Saxon Armoured Personnel Carrier



Saxons were used in the days of the Cold War by Infantry Regiments based in the UK. In the event of hostilities, they were to drive from the UK as fast as possible to reinforce the units based in Germany. They were first used in Exercise Lionheart in 1984 where they were driven from Caterick in Yorkshire through to Lower Saxony in Germany. After the success of this exercise, several hundred more were purchased.

These were a "battlefield taxi" designed to move troops under armour to the war zone, but not take part in any combat. They had the automotive components of a Bedford TM truck with an armoured body put over them. The British Army used them right through to 2005 where a small number were seen in use in Kabul in Afghanistan. They were withdrawn from service in 2008.



exclusive for the



www.pg-models.co.uk

www.ngaugesociety.com

Assembly

Fit the parts together using either a two part epoxy resin such as Araldite or Devcon, or with a cyanoacrylate Superglue.

Fit spare wheel underneath the side door

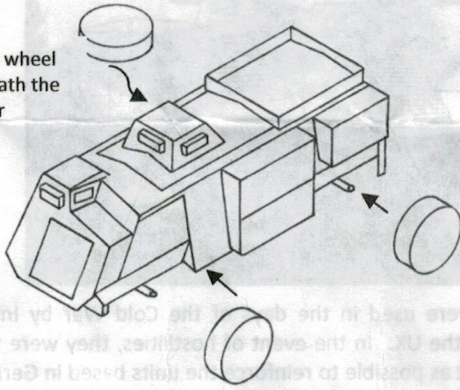

Painting

Prime the model with a light coat of grey primer, then apply either enamels or acrylics. (numbers refer to Humbrol enamels)

The standard colour is olive green 86, usually with a black 33 disruptive pattern on all corners and projections; or matt white 34 overall for use with the United Nations in Croatia .

Headlights and side lights
Silver 11

Tyres -
Dark Grey 32

Exhaust
Rust 113

Front and Rear Indicators
Orange 18

Rear Lights.
Red 19

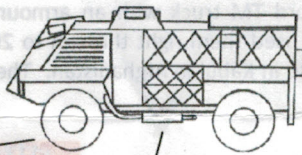

Suitable markings are available separately in the Transfer set from P G Models who also have a pack of stowage chocks to secure the vehicle to a railway wagon.