

INSTALLATION AND OPERATING INSTRUCTIONS NO 94762

For safety it is absolutely necessary that the following instructions are thoroughly read and observed.

■ RECEIPT

Please check delivery immediately on receipt for accuracy and damage. If damaged, please notify carrier immediately. Delayed notification may void any possible claim.

■ ACCESSORY INCLUDED IN THE DELIVERY

1 x GigaBox, 2x Flexible sleeve, 1x Discharge adapter - from square into circular ducted system

■ SAFETY INSTRUCTIONS

⚠ ATTENTION!

The equipment must be fully isolated from the power supply before any work is carried out on the unit. All electrical connections must be made in accordance with the relevant wiring diagram and only to be done by a qualified electrician. All relevant safety regulations, national standards and norms must be adhered to.

■ STORAGE

The following steps are to be taken when storing: Protect electrical motor by dry, air- and dustproof packing (plastic bags with drying agent and moisture indicators). The storage area must be waterproof, vibration-free and free of temperature variations.

When storing for several years or non rotation of motor an inspection of the bearings with possible relubrication and an installation inspection are absolutely necessary before starting operation.

An electrical test to VDE 0701 and VDE 0530 has to be carried out.

When transshipping check if the packing is adequate for method and manner of transportation.

Damages due to improper transportation, storage or putting into operation are not liable for warranty.

■ OPERATION/USE

Gigaboxes are designed to handle medium to high air volumes of normal or slightly dusty, aggressive and/or humid air against high pressure in most ventilation systems. The outlet of the fan can be changed to give exhaust straight through, exhaust through 1 side outlet and exhaust through 2 sides. This is achieved by moving the side panels and the transformation piece to the correct position for the desired outlet.

For operation under difficult conditions i.e. high humidity, longer period of standstill, high pollution, excessive working conditions through climatic, technical or electronic influences, further inquiry and operation release is necessary as the standard execution might not be suitable.

The insulation class, the IP rating and the maximum air flow temperature (at normal operation -TR and using speed regulation) are given on the fan name plate. The fan is limited for continuous operation S1 and frequent switching operations are not allowed. The fan may only be used for its intended purpose.

⚠ Using the fan to move heavily polluted air or in potential hazardous areas is not allowed!

■ IMPELLERS

Gigabox-Fans with sizes of 250 mm to 450 have backwards curved centrifugal impellers made of plastic with galvanised steel support plates.



Sizes 500 mm and larger have impellers made of aluminium.

The impeller and the external rotor motor as one unit are dynamically balanced to quality standard G 6.3 or 2.5 DIN ISO 1940 T.1.

■ OPERATION AS ROOM VENTILATION DEVICE

In order to achieve the desired fan performance (ambient temperatures of -40° to +40°C) a systematic air supply is essential.

■ PERFORMANCE DATA

- Electrical parameters

The motor rating plate provides information on the electrical data; this data is to be examined for its conformity to the local conditions.

- Acoustics

The noise data also refers to the above mentioned configuration. Adverse operating conditions etc. can lead to an increase of the given data.

■ ELECTRICAL CONNECTION

⚠ All work only in dead state. Electrical connection may only be carried out by specially trained and approved personnel. An all-pole mains switch with a minimum contact opening of 3 mm and Power-supply voltage and frequency must correspond to the data on the motor rating plate.

All relevant safety and installation regulations are to be observed.

■ SOUND LEVEL

The sound levels stated in the catalogue can differ considerably after installation as the sound pressure level depends on the absorption capacity of the room, the place of installation and other factors.

Sound reduction is possible by using sound attenuators and by speed regulation.

■ PROTECTION AGAINST ACCIDENTAL CONTACT

When installing observe the valid regulations for labour protection and accident prevention.

Any contact with rotating parts must be avoided. Make sure that no textiles (such as curtains) or other materials which could be sucked in, as for instance clothing are close to the suction area of the fan.

Depending on the installation conditions a contact safety device on the discharge side may be necessary.

Corresponding grilles are available as accessories. Fans protected by their installation in ventilation channels or closed aggregates do not need a protection grille, if the installation guarantees the same protection

(see DIN 31001 and 24167). We emphasize that the installer will be held responsible for accidents occurring as a result of missing protection devices.

■ AIR FLOW DIRECTION AND DIRECTION OF ROTATION

The Gigabox model ranges have a fixed direction of rotation, i.e. they are not reversible. The direction is indicated by an arrow on the units. Correct rotation must be ensured when running the fan. Incorrect direction of rotation leads to lower air volumes, increased noise levels and a higher electrical current which will harm the motor.

⚠ The fan should be installed to ensure desired air flow direction in the system.

The air flow direction of the fans can be determined by appropriate installation (see operation/use above). The discharge is possible in any direction by changing the discharge adapter and side panels to suit to desired result. Therefore most desired discharge options are available

■ SPEED CONTROL

All units are speed controllable using an electronic or a 5 step transformer controller. The 3 phase units can also be operated via star-delta connection giving 2 speed steps (accessory 2 speed switch DS 2 or motor protection unit M 4).

3-phase units are controllable with Helios frequency inverters (accessory). For safe operation a sinus filter on all phases must be installed between motor and inverter to protect the phases. When speed controlled, the maximum air flow temperature stated for speed controlled fans (TR) must not be exceeded. The suitable performances curves and controllers can be found on the equivalent catalogue page(s).

⚠ The use of the other brands, especially other electronic devices, can lead to malfunctioning and even failure of controller and/or fan. Controllers which have not been cleared by Helios are not liable for warranty and guarantee claims.

■ MOTOR PROTECTION

All Gigabox fans are manufactured with maintenance-free external rotor motors with built in thermal contacts, suitable for continuous operation S1, insulation class F.

All units should be connected to a suitable motor protection device (accessory). Only through this an approved motor protection is achieved.

■ MOUNTING

The standard fans are delivered as a complete unity, i.e. ready to install. With a raised installation position (not at ground level) the unit must be well secured to prevent any movement. The wall brackets GB-WK.. (accessory) can be used for secure installation at high level. For protected installation outdoors, the outdoor cover hood GB-WSD (accessory) must be mounted. With installation on a level surface put anti vibration mounts SDD-U (accessory) under each corner between casing and surface to avoid vibration transmission.

■ INSTALLATION

For installation of the Gigabox units in various positions please ensure secure, durable mounting of the unit as well as a free access to the terminal box and the motor. Positioning is made using integrated crane hooks. Removable panels allow inspection access from four sides. To prevent vibration transmission to buildings and ducting systems you can use flexible sleeves (included in delivery) between fan box and connecting ducting.



⚠ To achieve the given sound and power data, it is necessary when connecting the fan box to a ducting system to have at least twice the duct diameter of straight ducting before and after the fan box. Otherwise there may be a loss of performance and higher sound levels.

Important: The GigaBox must be assembled so that service and maintenance can be performed easily and safely.

■ CONDENSER-WATER DEVELOPMENT

Condensate formation is minimised by the double skinned panels with temperature insulating fibreglass infill.

In case of periodical use, moist and warm air and rapid temperature variations (intermittent service), condensate may built up in the duct and must be drained off. Subject to installation position it is possible to use the condensate collector GB-KW.. (accessory).

■ PUTTING INTO OPERATION

The following checks are to be carried out:

- Check for operation according to the intended purpose of the fan.
- Compare power supply voltage with data on the rating plate.
- Check if fan is securely mounted.
- Check all parts especially screws and nuts for tight fit.
- Check vibration free operation.
- Check free wheeling of impeller.
- Check on correct direction of rotation and correct direction of air flow.
- Check earth connection.
- Compare current consumption with data on the rating plate.

- Test protective conductor connection.
- Check sealing of the connection cable and clamping of the cable wires.
- Start operation only if all previous checks are passed and if protection against accidental contact with impeller is guaranteed.

■ MAINTENANCE

⚠ All servicing only in dead state.

Excessive deposit of dirt, dust, grease and other materials on the impeller, motor and especially between casing and impeller is to be avoided and has to be prevented by periodical cleansing. For maintenance purposes inspection doors and access openings must be provided in the duct system in a suitable place. The motors have maintenance free, long-lasting greased ball bearings.

■ TROUBLE SHOOTING

Triggering of motor overheat protection (TK) can indicate:

- built up of dirt or hard running impeller or ball bearing failure
- too high air flow temperature

Abnormal noises can mean

- wrong direction of rotation
- worn out ball bearings
- bad vibration isolation to other buildings and ducting systems
- hard running impeller or ball bearing failure

Vibration can originate from

- unbalanced or dirty impellers
- insufficient vibration isolation from buildings and ducting systems

Extreme reductions in performance can occur

- if resistance to air stream through ducting and accessories (grilles, shutters, filters etc.) is higher than designed.

■ ACCESSORIES

- **Wall bracket GB-WK ..**
for wall installation
- **External weather louver GB-WSG ..**
for side discharge.
- **Outdoor cover hood GB-WSD ..**
for protected installation outdoors
- **Condensate collector GB-KW ..**
with condensation spigot for connection to a flexible hose
- **Anti vibration mounts GB-SSD ..**
to avoid vibration transmission

■ ACCESSORIES, SWITCHES AND CONTROLLING DEVICES

The use of accessories not offered or recommended by Helios is not permitted. Any potential damage claims become void.

■ WARRANTY – EXCLUSION OF LIABILITY

If the preceding instructions are not observed all warranty claims and accommodation treatment are excluded. This also applies to any liability claims extended to the manufacturer.

■ CERTIFICATES

Our products are manufactured in compliance with applicable European standards and regulations.



fig. 1
GigaBox inclusive accessories

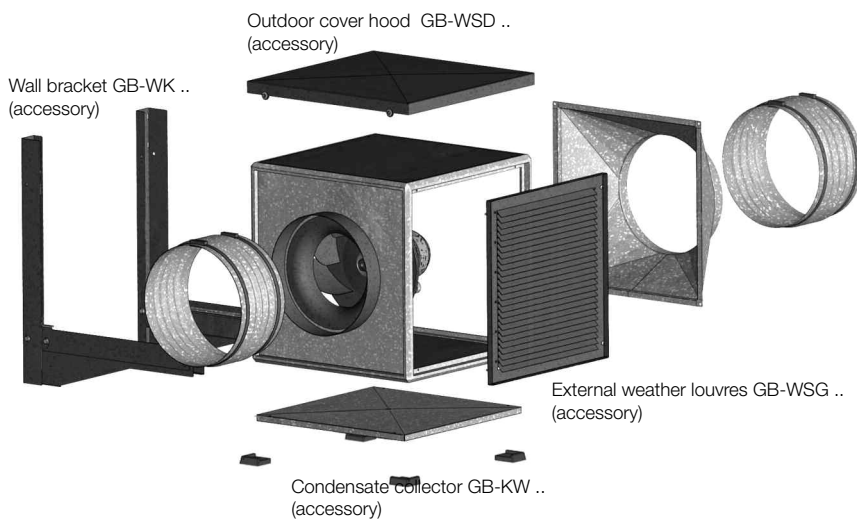

fig. 2

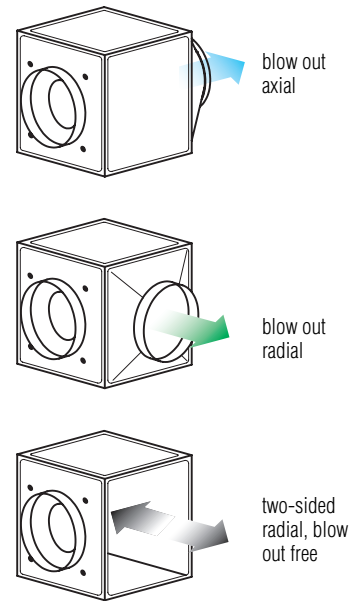
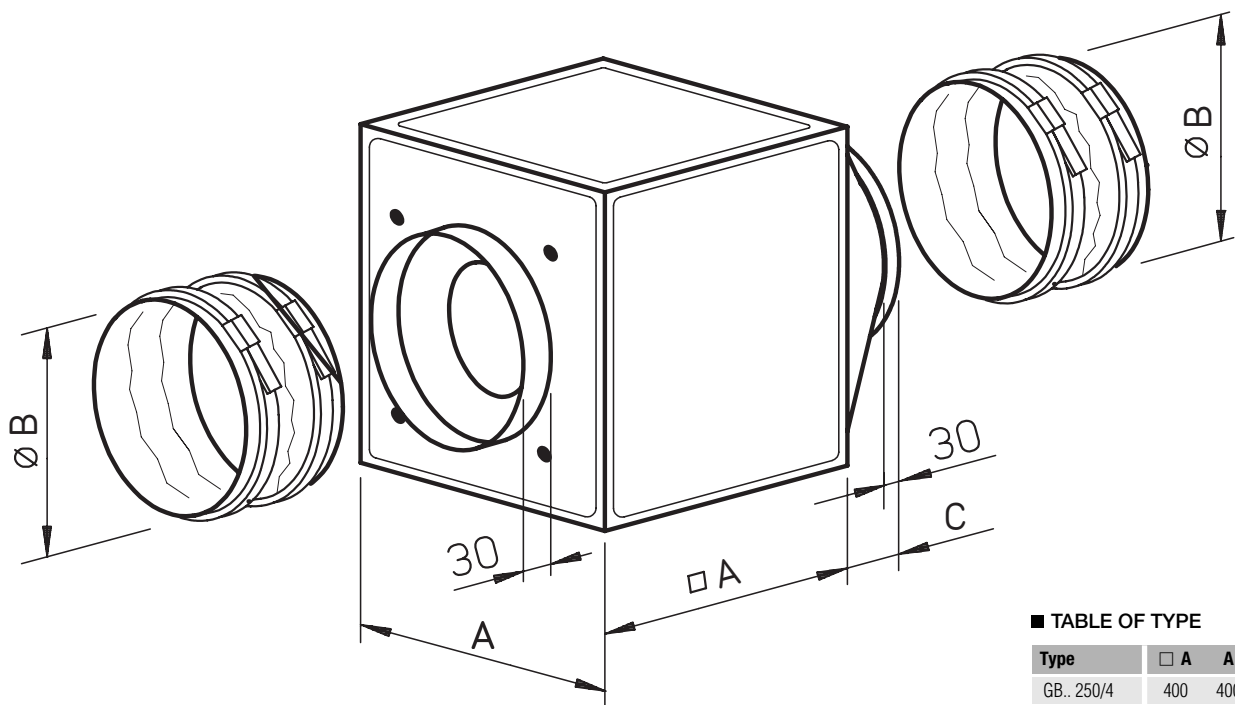

fig. 3



■ TABLE OF TYPE

Type	□ A	A	Ø B
GB.. 250/4	400	400	250
GB.. 315/4	500	500	315
GB.. 355/4..	500	500	355
GB.. 400/4..	670	670	400
GB.. 450/4..	670	670	450
GB.. 500/..	670	670	500
GB.. 560/..	800	800	560
GB.. 630/..	800	800	630
GB.. 710/6/6	1020	1020	710

Dimensions in mm

■ WIRING DIAGRAM

SS-864
GBW ..
Alternating current fan with thermal contact in series.

U1 - brown (BN) Z2 - orange (OG)
U2 - blue (BU) TK - white (WH) or yellow (YE)
Z1 - black (BK) PE - yellow/green (YE/GN)

TK in series only with motor < 6A

U1 - blue (BU)
U2 - black (BK)
Z - brown (BN)
PE - yellow/green (YE/GN)

SS-923
GBW 250/4 and 315/4
Single phase A, C, motor with operating capacitor and thermal contact.

TK in series only with motor < 6A

U1 - brown (BN)
U2 - blue (BU)
Z1 - black (BK)
Z2 - orange (OG)
TK - white (WH) or yellow (YE)
PE - yellow/green (YE/GN)

SS-865
GBW 500/4
Alternating current fan carried out with thermal contact in order to connect full motor protection units.

SS-867
GBD ..
3~ rotary current, rotation speed switchable, double-rotating, with star-delta connexion 400 V / 400 V and thermal contact.

U1-braun (BN)
V1-blau (BU)
W1-schwarz (BK)
U2-rot (RD)
V2-grau (GY)
W2-orange (OG)
TK-weiß (WH)
PE-gelb/grün (YE/GN)

U1-braun (BN)
V1-blau (BU)
W1-schwarz (BK)
U2-rot (RD)
V2-grau (GY)
W2-orange (OG)
TK-weiß (WH)
PE-gelb/grün (YE/GN)

Service und Information