



JS-Sk Series Single Phase Sewage Cutter Pumps



JS-SK series are heavy duty submersible sewage cutter impeller pumps allowing soft

solids to be passed through the pump body to waste.

- Single channel tungsten carbide tipped impeller capable of cutting soft organic solids
- Cutting impeller had higher head than vortex impeller
- Supplied as a free standing pump. Guide rails available for some models
- Cast iron pump body, impeller, lower motor bearing/seal housing and motor top cover.
- Stainless steel shaft and motor casing.
- Twin mechanical seals, the lower seal is made of silicon carbide and the upper seal carbon/ceramic. An extra lip seal is installed to help prevent abrasives such as sand, dirt and silt from entering the seal chamber.
- Complete with 10 metres of power cable.
- Hose tails are supplied with all models.
- Floats available as extras



MODEL	WEIGHT	DIMENSIONS	FLOW/HEAD	POWER	SOLIDS
	Kg	H x W x L	LM/HM	kW	DIAMETER MAX SOLIDS
JS-750 SK MAN 230v 2"	29.4	530 x 190 x 310	400/14	0.75	30mm
JS-750 SK AUTO 230v 2"	29.4	530 x 190 x 310	400/14	0.75	30mm
JS-750 SK MAN 110v 2"	29.4	530 x 190 x 310	400/14	0.75	30mm
JS-750 SK AUTO 110v 2"	29.4	530 x 190 x 310	400/14	0.75	30mm
JS-1500 SK MAN 230v 2"	36.4	530 x 240 x 360	800/16	1.5	35mm
JS-1500 SK AUTO 230v 2"	36.4	530 x 240 x 360	800/16	1.5	35mm

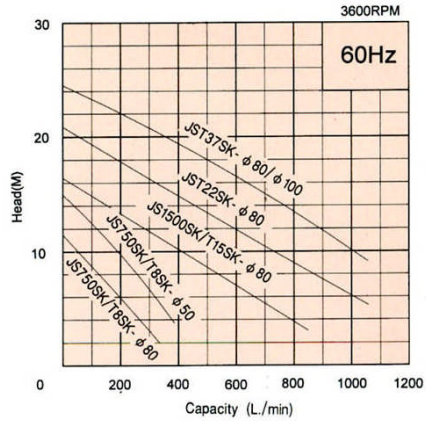
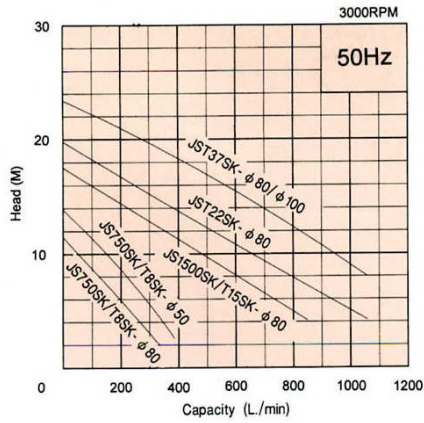

Specifications 50/60Hz

Pump Type	Outlet Diameter Inch(mm)	Output KW	Voltage 50Hz or 60Hz	Continuous		Cable c*awg*m/ c*mm ² *m	Weight		Max Solids(mm)	
				Head M	Capacity L./min		Free standing KG	SR- Model KG	50Hz	60Hz
JS750 SK	2"(50)	0.75	1 Phase 100V } 240V	7	250/300	3*14awg*10	30	8	21	21
JS750 SK	3"(80)	0.75		6	200	3*14awg*10	30	24.6	21	21
JS1500 SK	3"(80)	1.5		8	600/550	3*14awg*10	41	24.6	44	40
JST8 SK	2"(50)	0.75	3 Phase 200V } 480V	7	250/300	4*1.25*10	28.5	8	21	21
JST8 SK	3"(80)	0.75		6	200	4*1.25*10	28.5	24.6	21	21
JST15 SK	3"(80)	1.5		8	600/550	4*1.25*10	37	24.6	44	40
JST22 SK	3"(80)	2.2		8	800/870	4*2.0*10	47	24.6	44	40
JST37 SK	3"(80)/4"(100)	3.7		10	950/1000	4*2.0*10	52	24.6/38.9	35	44

Pump Type	Discharge bore	Pump section						Operating water level	
		d	A	A1	B	D	H	W1	W2
JS750 S / SK	2"(50)	310	185	160	195	495	445	130	
JS750 S / SK	3"(80)	355	205	195	195	520	470	155	
JS1500 S / SK	3"(80)	385	220	180	240	505	455	140	
JST8 S / SK	2"(50)	310	185	160	195	435	385	130	
JST8 S / SK	3"(80)	355	205	195	195	460	410	155	
JST15 S / SK	3"(80)	385	220	180	240	470	420	140	
JST22 S / SK	3"(80)	405	230	190	240	520	430	155	
JST37 S / SK	3"(80)	405	230	210	250	555	475	185	
JST37 S / SK	4"(100)	405	230	210	250	555	475	185	
JST55 S	4"(100)	570	340	315	260	690	630	250	
JST75 S	4"(100)	645	380	340	260	760	700	250	
JST75 S	6"(150)	720	420	375	260	760	700	250	

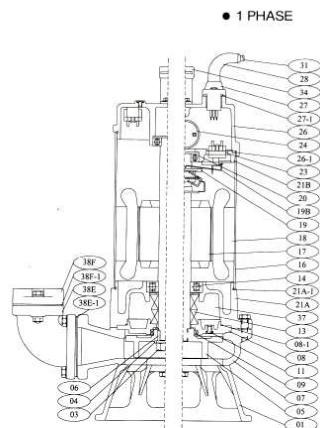
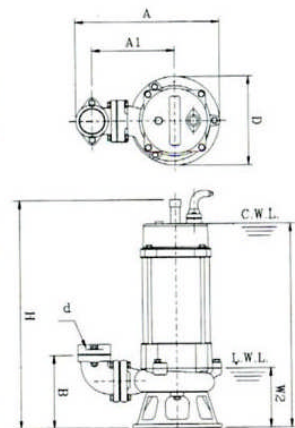

NO.	DESCRIPTION	NO.	DESCRIPTION
01	STAND	21A	MOTOR BOTTOM COVER
03	NUT	21A-1	ORING
04	WASHER	21B	MOTOR UPPER COVER
05	IMPELLER	23	OVERLOAD PROTECTOR
06	KEY	24	CONDENSER
07	PUMP HOUSING	26	UPPER COVER
08	OIL CHAMBER	26-1	ORING
08-1	GASKET	27	CABLE GLAND
09	LIP SEAL (LOWER)	27-1	GASKET
11	PLUGS	28	RUBBER SLEEVE
13	MECHANICAL SEAL	31	CABLE
14	BEARING (BOTTOM)	34	HANDLE
16	MOTOR CASING	37	OIL
17	ROTOR SHAFT	38E	ELBOW
18	STATOR	38E-1	GASKET
19	GOVERNOR SWITCH	38F	FLANGE
19B	GOVERNOR SWITCH PLATE	38F-1	GASKET
20	BEARING (UP)		