

WIRING CONNECTIONS

OUTPUT WIRING CONNECTION FOR REMOTE ALARM:

- 1 = Alarm: Normally Open Contact
- 2 = Alarm: Common
- 3 = Alarm: Normally Closed Contact

OUTPUT WIRING CONNECTION FOR THE PUMP:

- 4 = OUTPUT FOR NEUTRAL PUMP WIRE
- 5 = OUTPUT FOR LIVE PUMP WIRE
- 6 = EARTH CONNECTION FOR PUMP WIRE
- 7 = EARTH CONNECTION FOR THE POWER SUPPLY

INPUT WIRING CONNECTION FOR THE POWER SUPPLY:

- 8 = INPUT PHASE WIRE POWER SUPPLY
- 9 = NEUTRAL WIRE POWER SUPPLY

SENSORS INPUTS :

13=C - 14=H2 - 15=L2 - 16=H - 17=L - 18=C

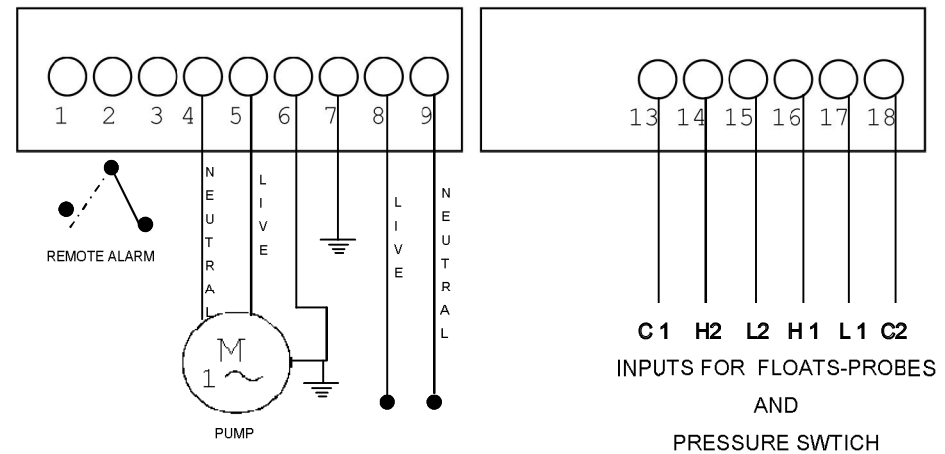
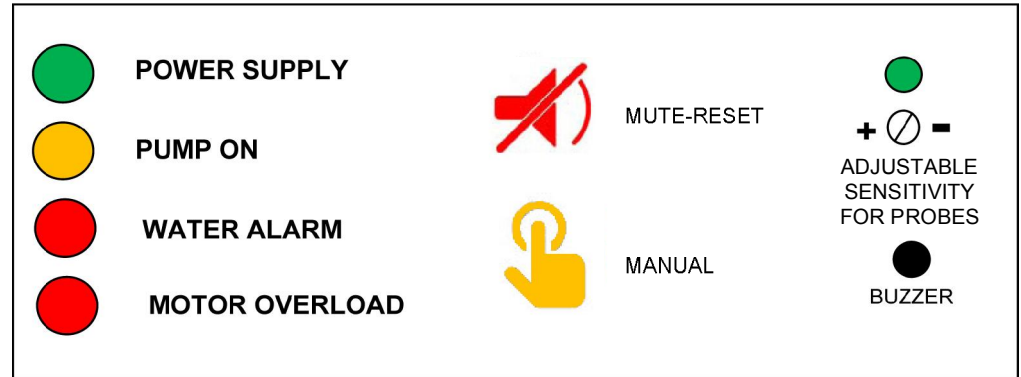
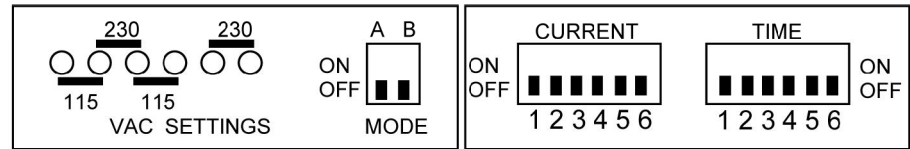

MODE:

- A=OFF B=OFF : **NO FLOOD FUNCTION**
- A=OFF B=ON : **DRAINAGE FUNCTION**
- A=ON B=OFF : **BOOSTER FUNCTION**
- A=ON B=ON : **FILLING FUNCTION**

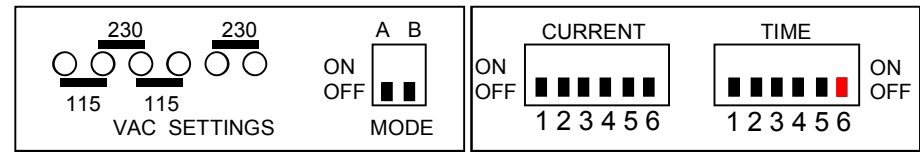

CURRENT

- 1 = 0.5A
- 2 = 1A
- 3 = 2A
- 4 = 4A
- 5 = 8A

6 = NOT USED

EXAMPLE: For setting the motor protection CURRENT setting to 5.5 amperes, move the dip switches 1, 2, 4, to ON position.

TIME:

- 1 = 2s
- 2 = 4s
- 3 = 8s
- 4 = 16s
- 5 = 32s

6 = BUZZER OFF – ON

EXAMPLE: For setting the TIME for the motor switching OFF to 10 seconds, move the dip switches 1 and 3 to ON position.

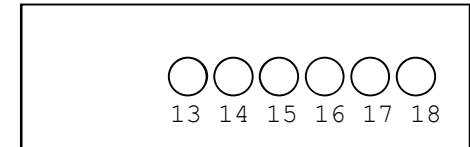
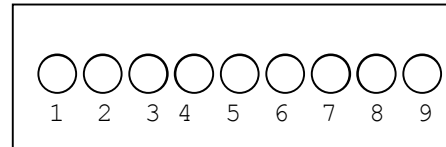
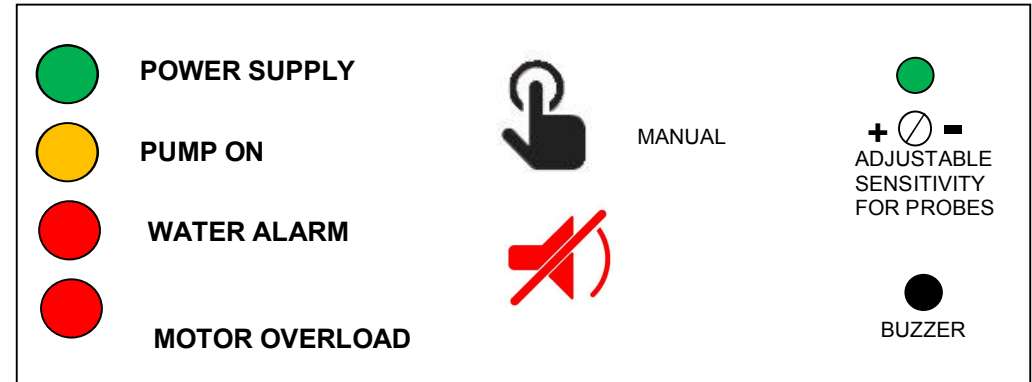

OUTPUT WIRING CONNECTION FOR REMOTE ALARM:

- 1 = Alarm: Normally Open Contact
- 2 = Alarm: Common
- 3 = Alarm: Normally Closed Contact

OUTPUT WIRING CONNECTION FOR THE PUMP:

- 4 = OUTPUT FOR NEUTRAL PUMP WIRE
- 5 = OUTPUT FOR LIVE PUMP WIRE
- 6 = EARTH CONNECTION FOR PUMP WIRE
- 7 = EARTH CONNECTION FOR THE POWER SUPPLY

INPUT WIRING CONNECTION FOR THE POWER SUPPLY:

- 8 = INPUT LIVE WIRE POWER SUPPLY
- 9 = NEUTRAL WIRE POWER SUPPLY

INPUTS FOR FLOATS-PROBES-PRESSURE SWITCH

- 13=C1 - 14=H2 - 15=L2 - 16=H1 - 17=L1 - 18=C2

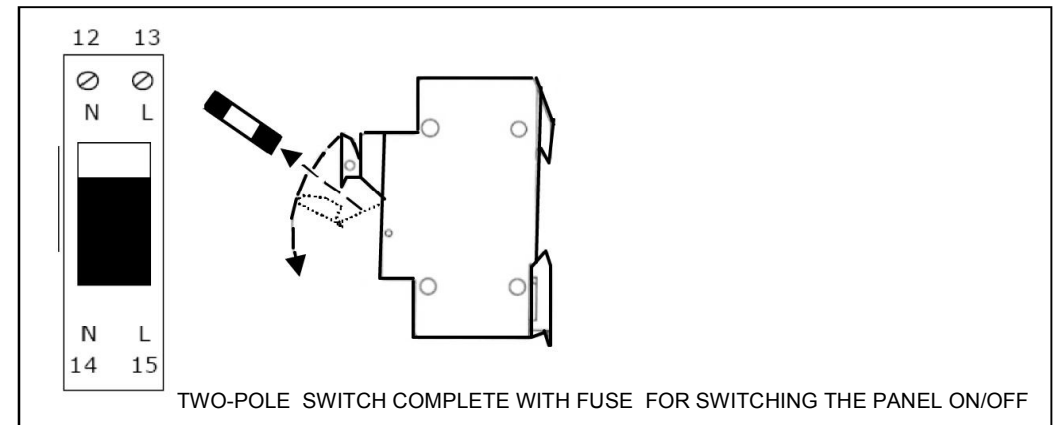

PROGRAM SWITCHES MODE FUNCTION

NO FLOOD FUNCTION: A=OFF B= OFF

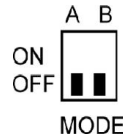

DRAINAGE FUNCTION: A=OFF B=ON

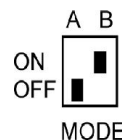

BOOSTER FUNCTION: A=ON B=OFF

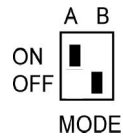

FILLING FUNCTION: A=ON B=ON

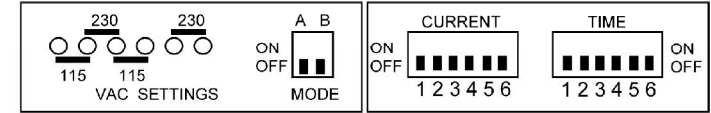
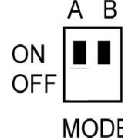

	POWER SUPPLY		MUTE-RESET		ADJUSTABLE SENSITIVITY FOR PROBES
	PUMP ON		MANUAL		BUZZER
	WATER ALARM				
	MOTOR OVERLOAD				

OVERLOAD PROTECTION CURRENT VALUE SWITCHES POSITION

- 1 = 0.5 A
- 2 = 1 A
- 3 = 2 A
- 4 = 4 A
- 5 = 8 A
- 6 = NOT USED

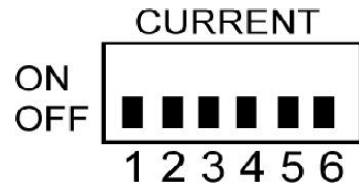

EXAMPLE FOR 5.5 AMPERES

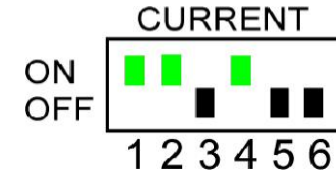

EXAMPLE FOR 4 AMPERES

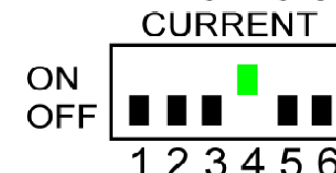

EXAMPLE FOR 10 AMPERES

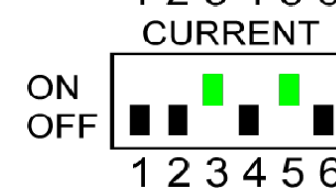

EXAMPLE FOR 2.5 AMPERES

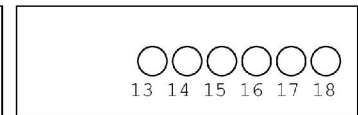
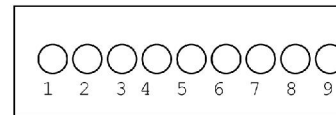
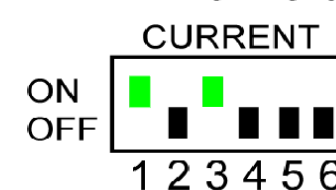

BUZZER OFF / ON

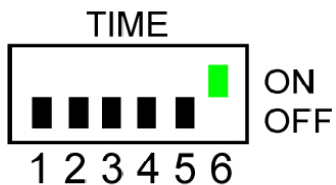

The Buzzer switches **ON** with the water level alarm and with the overload motor protection. If needed it is possible to switch it **OFF** changing the position of the dip switch n° 6 from **ON** (on the time side) to **OFF** position.

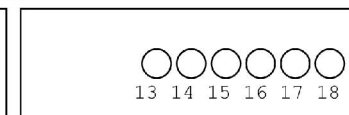
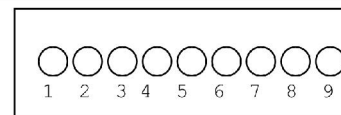
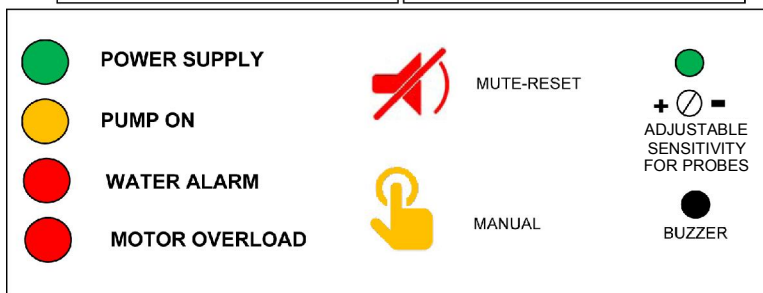
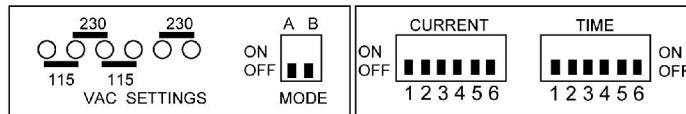

TIMER — DELAYED PUMP OFF SWITCHING

- 1 = 2s
- 2 = 4s
- 3 = 8s
- 4 = 16s
- 5 = 32s
- 6 = BUZZER OFF / ON

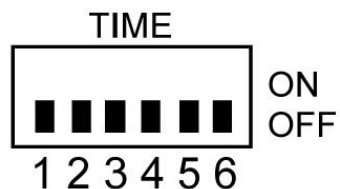

EXAMPLE FOR 6 SECONDS

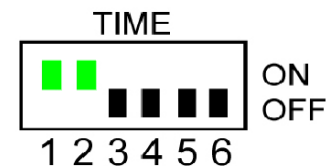

EXAMPLE FOR 10 SECONDS

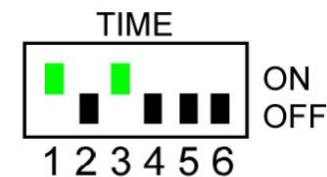

EXAMPLE FOR 20 SECONDS

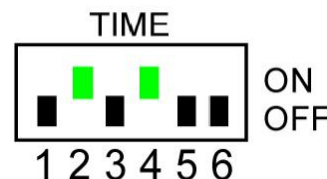

EXAMPLE FOR 30 SECONDS

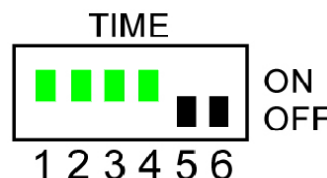

FUNCTION

DESCRIPTION

NO FLOOD FUNCTION PUDDLE BUDDY SENSOR

WIRING COLOURS POLE PROBE

YELLOW WIRE = NOT USED

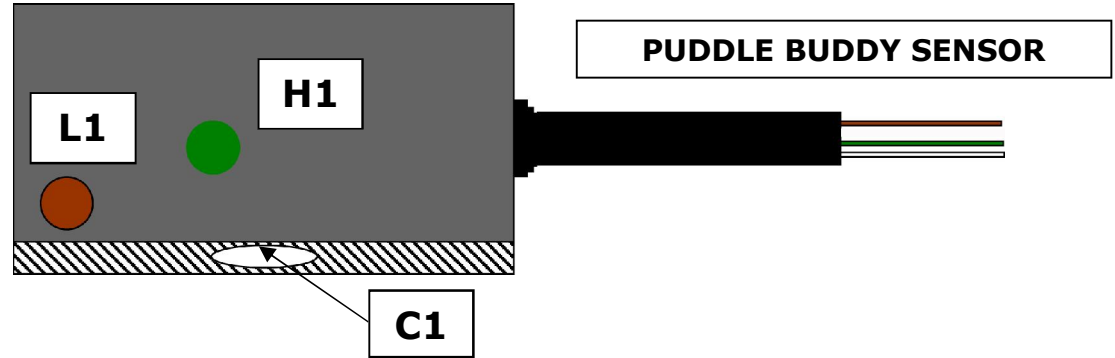

1 **2 POLE FLOOR PROBE**

MODE 00 A=OFF B=OFF

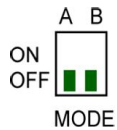

Timer from 0 to 62s
Water alarm relay ON
Buzzer EXCLUDABLE (see pag. 5)

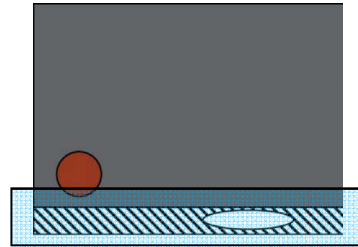

Probe connection:

C = WHITE = 13
L = BROWN = 16
YELLOW WIRE = NOT USED
GREEN COLOUR = NOT USED



The pump starts when the water reaches L point and stops when the water level is under L point + the delayed time set.

Alarm output relay: switches on for all the pump working time.

Buzzer: switches on for all the pump working time

2 **3 POLE FLOOR PROBE**

MODE 00 A=OFF B=OFF

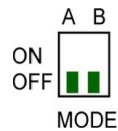

Timer from 0 to 62s
Water alarm relay ON
Buzzer EXCLUDABLE (see pag. 5)

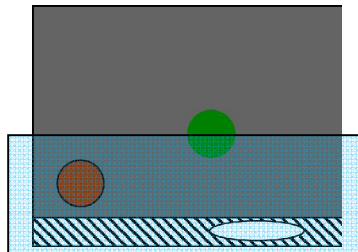

Probe connection:

C = WHITE = 13
L = BROWN = 17
H = GREEN = 16
YELLOW WIRE = NOT USED



The pumps starts when the water reaches H point and stops when the water level is under the L point + the delayed time set.

Alarm output relay: switches on for all the pump working time.

Buzzer: switches on for all the pump working time

3

DRAINAGE

4 POLE PROBE vertical position

MODE 01 A=OFF B=0N

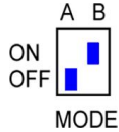

Buzzer **EXCLUDABLE** (see pag.5)
 Water alarm relay **ON**
 Timer **EXCLUDED**

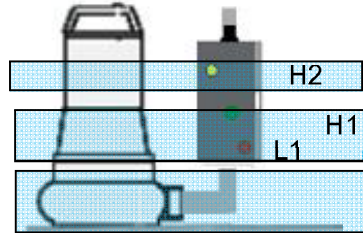

Probe connection:

C1 = WHITE = 13
 L1 = BROWN = 17 STOP LEVEL
 H1 = GREEN = 16 START LEVEL
 H2 = YELLOW =14 LEVEL TOO HIGH ALARM

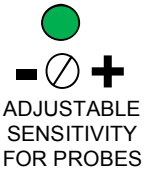

The pump starts when the water reaches H1 point and stops when the water is under the L1 point.

If the water reaches the H2 point (LEVEL TOO HIGH) it switches the alarm output relay ON, then switches it OFF when the level is under this point.

4

DRAINAGE

1 Float switch operation

MODE 01 A=OFF B=0N

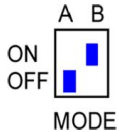

Buzzer **EXCLUDED**
 Water alarm relay **EXCLUDED**
 Timer **EXCLUDED**

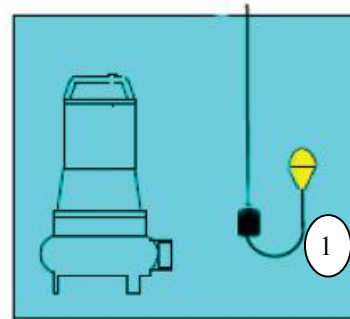

Float switch connection:

C1 = 13 COMMON WIRE
 H1 = 16 CLOSED WIRE CONTACT FLOAT UP POSITION

The pump starts when the float switch closes the contact and stops when the float switch opens the contact.

5

DRAINAGE

2 float switches for sewage

START and STOP function
MODE 01 A=OFF B=0N

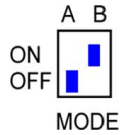

Buzzer EXCLUDED
Water alarm relay EXCLUDED
Timer EXCLUDED

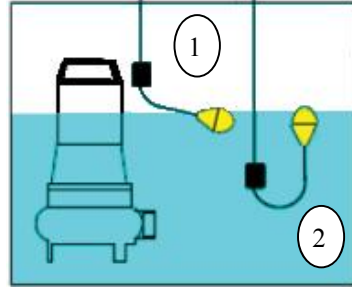

STOP float switch (2) connection:

C1 = 13 COMMON WIRE
L1 = 17 CLOSED WIRE CONTACT FLOAT UP POSITION

START float switch (1) connection:

C2 = 18 COMMON WIRE
H1 = 16 CLOSED WIRE CONTACT FLOAT UP POSITION

The pump STARTS when the START float switch (1) closes the contact and the pump STOPS when the STOP float switch (2) opens the contact.

6

DRAINAGE

TWO-POLE probes for
START and STOP function

MODE 01 A=OFF B=0N

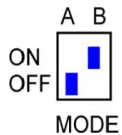

Buzzer EXCLUDED
Water alarm relay EXCLUDED
Timer EXCLUDED

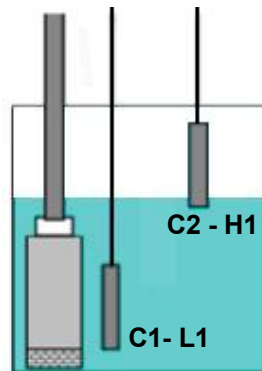

TWO-POLE probe STOP level point:

C1= 13
L1 = 17

TWO-POLE probe START level point:

C2 = 18
H1 = 16

The pump starts when the water reaches the START level point H1 and STOPS when the water level is under L1 level point.



7

DRAINAGE

1 START/STOP float switch and 1 float switch for HIGH LEVEL ALARM

MODE 01 A=0FF B=0N

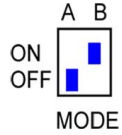

Buzzer ON or OFF
Water alarm relay ON
Timer EXCLUDED

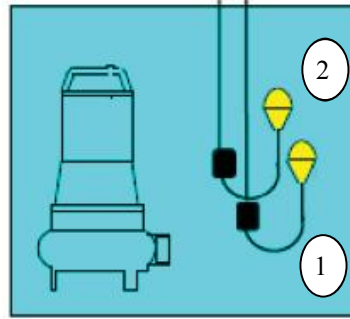

START /STOP float switch 1:

C1 = 13 COMMON WIRE
H1 = 16 CLOSED WIRE CONTACT FLOAT UP POSITION

HIGH LEVEL ALARM float switch 2:

C2 = 18 COMMON WIRE
H2 = 14 CLOSED WIRE CONTACT FLOAT UP POSITION

The pump starts when the **START/STOP float switch (1)** closes the contact and the pump stops when it opens the contact.

Alarm output relay: switches **ON** when the **HIGH LEVEL ALARM float switch (2)** closes the contact and switches **OFF** when it opens it.

8

DRAINAGE

2 float switches for sewage START and STOP function and 1 float switch for HIGH LEVEL alarm

MODE 01 A=0FF B=0N

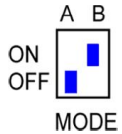

Buzzer ON or OFF
Water alarm relay ON
Timer EXCLUDED

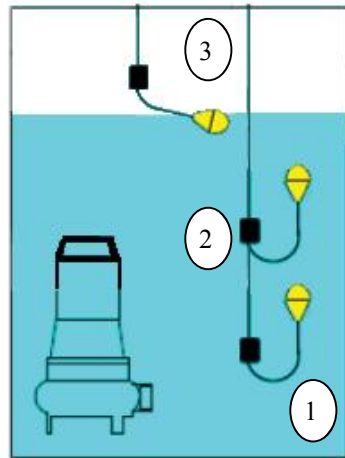

STOP level point:

C1 = 13 COMMON WIRE
L1 = 17 CLOSED WIRE CONTACT FLOAT UP POSITION

START level point:

C2 = 18 COMMON WIRE
H1 = 16 CLOSED WIRE CONTACT FLOAT UP POSITION

HIGH LEVEL ALARM point:

C3 = 18 COMMON WIRE
H2 = 14 CLOSED WIRE CONTACT FLOAT UP POSITION

The pump **STARTS** when the **START float (2)** closes the contact and **STOPS** only when the **STOP float (1)** opens the contact.

Alarm output relay: switches **ON** when the **HIGH LEVEL ALARM switch (3)** closes and switches **OFF** when it opens.

9

DRAINAGE

3 single pole probes for START and STOP function and 1 probe for HIGH LEVEL alarm

MODE 01 A=OFF B=0N

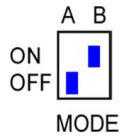

Buzzer ON or OFF
Water alarm relay ON
Timer EXCLUDED

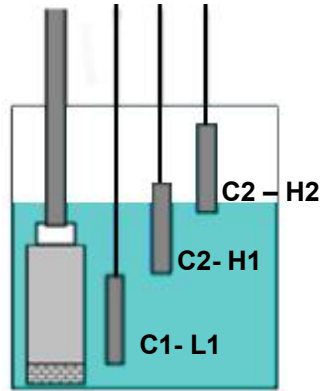

TWO-POLE probe STOP level point:

C1 = 13
L1 = 17

TWO-POLE probe START level point:

C2 = 18
H1 = 16

TWO-POLE probe level TOO HIGH ALARM point:

C2 = 18
H2 = 14

The pump STARTS when the level point reaches H1, STOPS when the water level point is under the L1 probe.
Alarm output relay: switches ON when the water reaches the HIGH LEVEL ALARM probe H2 and switches OFF when the water level point is under the H2 probe.



10

BOOSTER

START and STOP pressure switch and 1 float switch for DRY RUNNING control

MODE 10 A=0N B=0FF

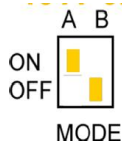

Buzzer ON or OFF
Water alarm relay ON
Timer EXCLUDED

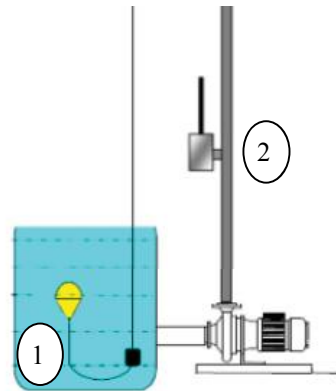

DRY RUNNING float switch:

C1 = 13 FLOAT SWITCH COMMON WIRE
H1 = 16 CLOSED WIRE CONTACT FLOAT UP POSITION

START/STOP pressure switch: C2 – H2 = 18 – 14

The pump STARTS when the PRESSURE SWITCH (2) closes the contact and STOPS when it opens, only if the DRY RUNNING float switch (1) is closed.

Alarm output relay: switches ON when the DRY RUNNING float switch (1) opens the contact and switches OFF when it closes.

11 BOOSTER

START and STOP pressure switch and 2 TWO-POLE probes for dry running

MODE 10 A=0N B=0FF

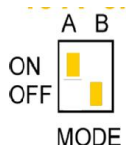

Buzzer ON or OFF
Water alarm relay ON
Timer EXCLUDED

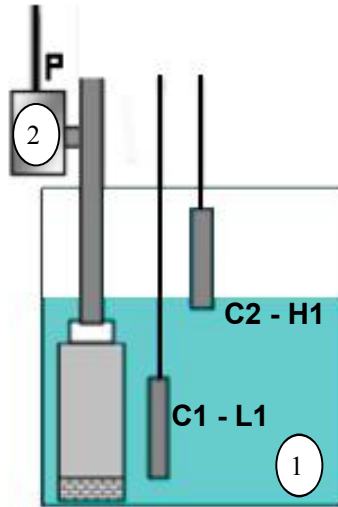

LOW LEVEL POINT dry running control:

C1 = 13
L1 = 17

HIGH LEVEL POINT dry running control:

C2 = 18
H1 = 16

START/STOP pressure switch: C2 - H2 = 18 - 14

The pump **STARTS** when the **PRESSURE SWITCH (2)** closes the contact **ONLY** if the water reaches the **H1** probe and the water level maintains the **L1** probe under water.

Alarm output relay: switches ON when the water is under the **L1** probe and is still **ON** if the water doesn't reach the **H1** probe also.



12 FILLING

FILLING control with 3 single pole probes
DRY RUNNING with 3 single pole probes

MODE 10 A=0N B=0N

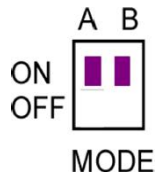

Buzzer ON or OFF
Water alarm relay ON
Timer EXCLUDED

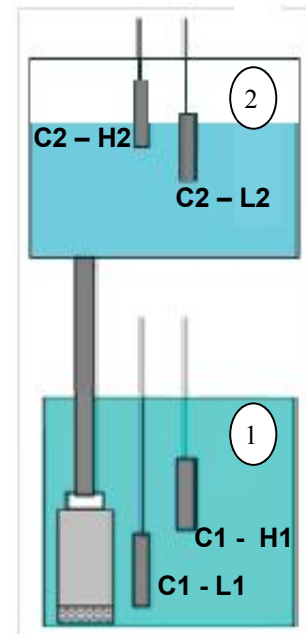

LOW LEVEL POINT dry running control:

C1 = 13
L1 = 17

HIGH LEVEL POINT dry running control:

C1 = 13
H1 = 16

FILLING LOW LEVEL point

C2 = 18
L2 = 15

FILLING HIGH LEVEL pole probe

C2 = 18
H2 = 14

The pump **STARTS** when the water level is under **L2** and **STOPS** when the water is over the **H2**, **ONLY** if the water is over the level point **H1**, and maintains the Low level point **L1** under water.

Alarm output relay: switches ON when the water is under the **L1** probe and remains **ON** if the water doesn't also reach the **H1** probe.



13

FILLING

FILLING control with 1 float switch
DRY RUNNING with 2 TWO-POLE probes

MODE 10 A=0N B=0N

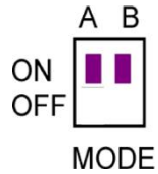

Buzzer ON or OFF
Water alarm relay ON
Timer EXCLUDED

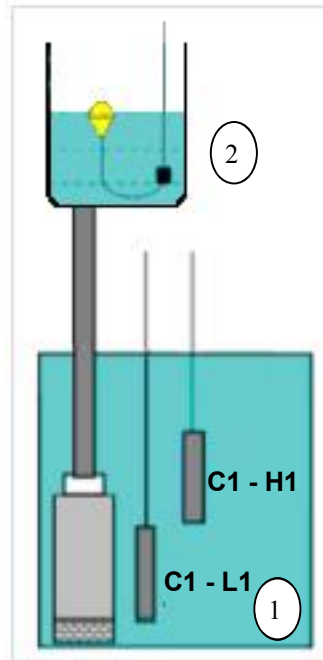

LOW LEVEL POINT dry running control:
C1 = 13
L1 = 17
HIGH LEVEL POINT dry running control:
C1 = 13
H1 = 16

MAKE AN ELECTRIC LINK BRIDGE ON: C = 18 H2 = 14

FILLING float switch:
C2 =18 COMMON WIRE
L2 = 15 CLOSED WIRE CONTACT FLOAT UP POSITION

The pump starts when the FILLING float switch (2) opens the contact and STOPS when it closes, ONLY if the water reaches the H1 level point and maintains the L1 level point under water.

Alarm output relay: switches ON when the water is under the L1 probe and is still ON if the water doesn't also reach the H1 probe.



14

FILLING

FILLING control with 3 single pole probes
DRY RUNNING control with 1 float switch control

MODE 10 A=0N B=0N

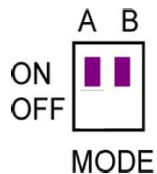

Buzzer ON or OFF
Water alarm relay ON
Timer EXCLUDED

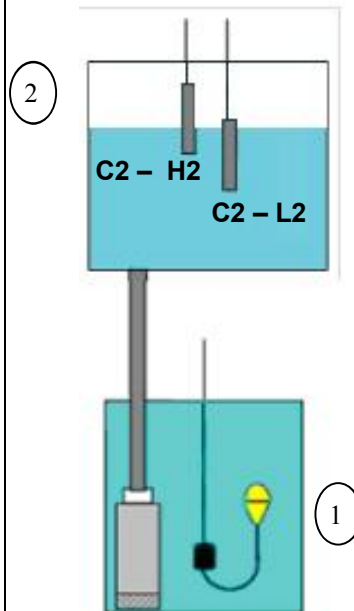

FILLING LOW LEVEL point
C2 = 18
L2 = 15
FILLING HIGH LEVEL pole probe
C2 = 18
H2 = 14

Dry running float switch:
C1 = 13 COMMON WIRE
H1 = 16 CLOSED WIRE CONTACT FLOAT UP POSITION

The pump STARTS when the water level is under L2 and STOPS when the water is over the H2, ONLY if the DRY RUNNING FLOATING SWITCH is closed.

Alarm output relay: switches ON when the DRY RUNNING float switch (1) contact is opened and switches OFF when closes.



15

FILLING

FILLING control with 1 float switch
and DRY RUNNING control with 1
float switch control

MODE 10 A=0N B=0N

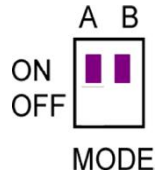

Buzzer ON or OFF
Water alarm relay ON
Timer **EXCLUDED**

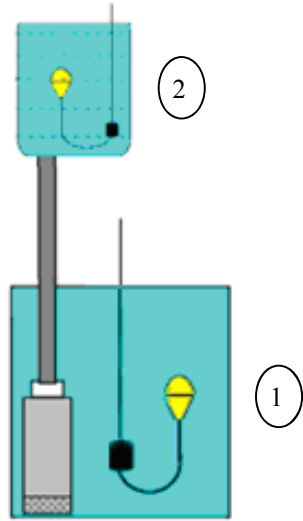

FILLING float switch:

C2 =18 COMMON WIRE

L2 = 15 CLOSED WIRE CONTACT FLOAT UP POSITION

MAKE AN ELECTRIC LINK BRIDGE ON: C = 18 H2 = 14

DRY RUNNING float switch :

C1 = 13 COMMON WIRE

H1 = 16 CLOSED WIRE CONTACT FLOAT UP POSITION

The pump starts when the FILLING SWITCH (2) opens the contact and STOPS when closes, ONLY if the DRY RUNNING control SWITCH (1) is closed.

Alarm output relay: switches ON when the DRY RUNNING floating switch (1) contact is opened and switches OFF when closes.