

# VAN ACCESSORIES

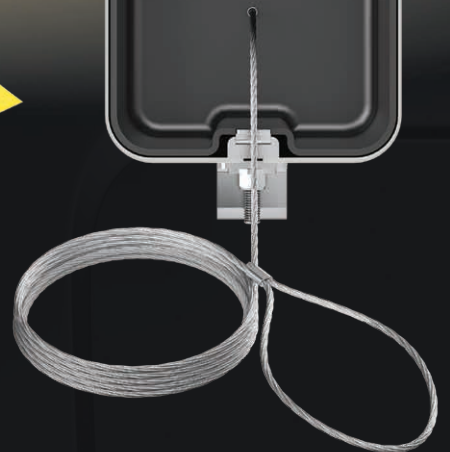
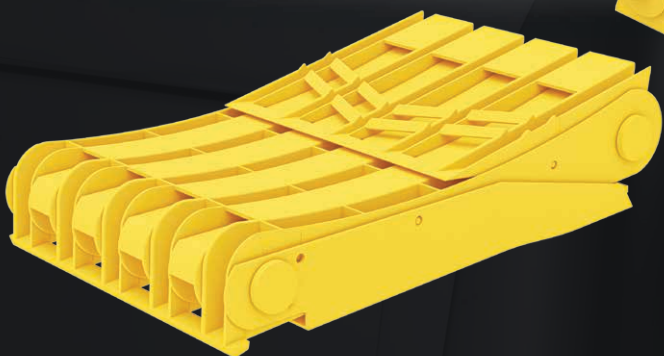
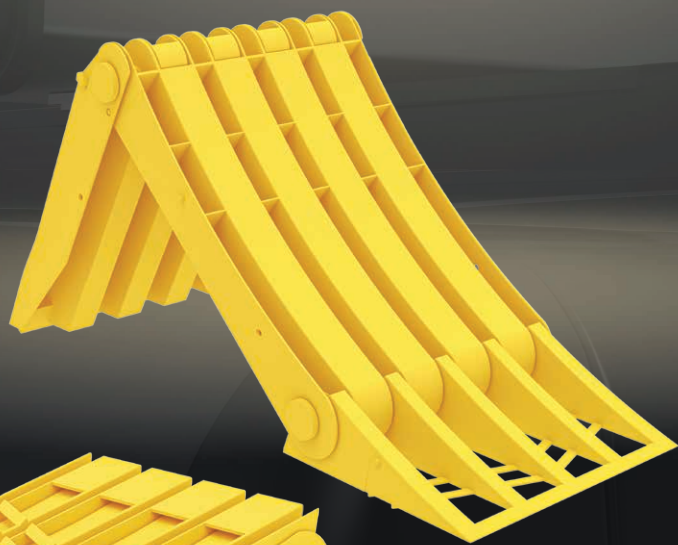

**NEW**

# LOKHEN CUBY ALUMINIUM TUBE CARRIER

Aluminium Tube - Customisable - Scratch Resistant Plastic End Caps - Waterproof - Secure Locking System



## Cuby Puller

Tube puller kit for squared carrying tube

Code	L mm	B mm	H mm	Volume	Max load	Weight
LKTC CUBY 2220	2220	166	200	78×15 mm tubes	25 kg	8.32
LKTC CUBY 3220	3220	166	200	78×15 mm tubes	50 kg	11.07
LKTC CUBY 4220	4220	166	200	78×15 mm tubes	75 kg	13.81

Please Contact us for Non-Standard or Other Sizes

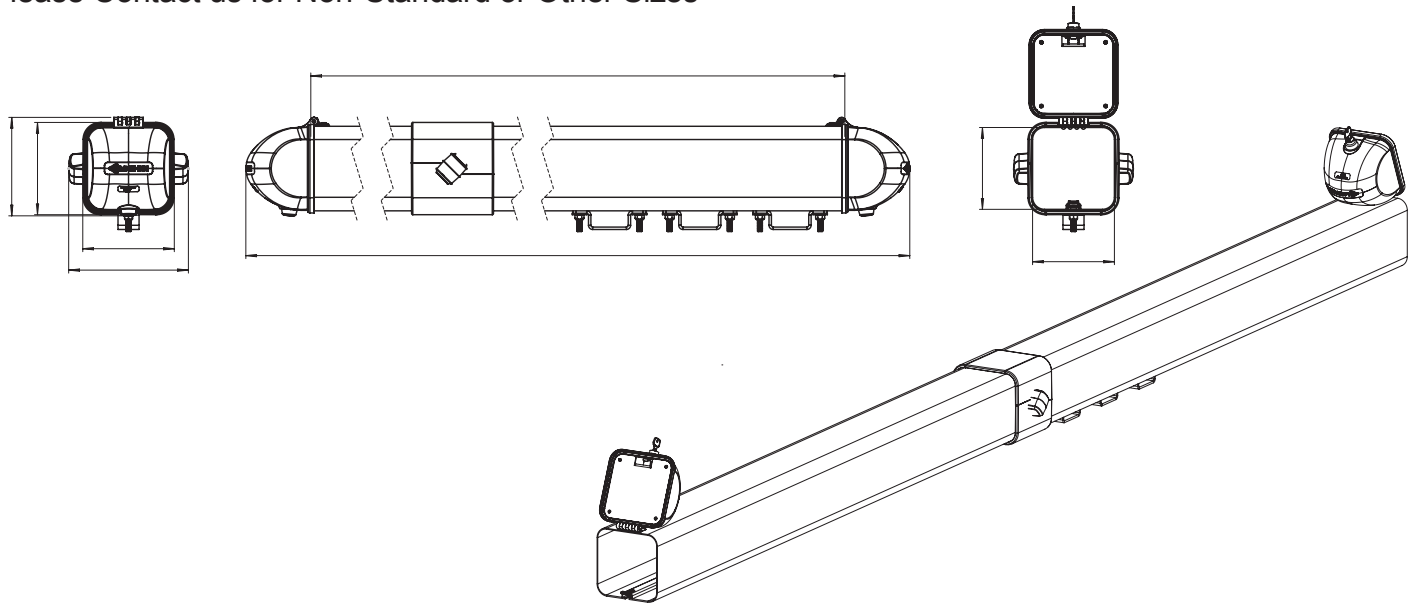

# BAWER ARMO VAN SECURITY LOCK

The BAWER ARMO van security lock represents the latest innovation in cargo van protection, offering a mix of strength, reliability and security.

- Burglar-proof design and elongated shape (17cm) limiting the bending of the doors in the event of a break-in
- Burglar-proof armour with protective steel spheres
- PlusNut rivets guarantee strong fastening even on thin metal sheets
- Anti-Drill defender
- Non-accessible micro-cast stainless steel central body
- Locking cam and pin (Ø 8mm) resistant to all burglary attacks
- Key EN1305:2015 with 15 million combinations, burglar-resistant, anti-bumping and anti-picking thanks to pistons placed on 3 axis geometry
- Robust design for a visual deterrent effect
- Captive key system
- Suitable for all van types.



Table information????

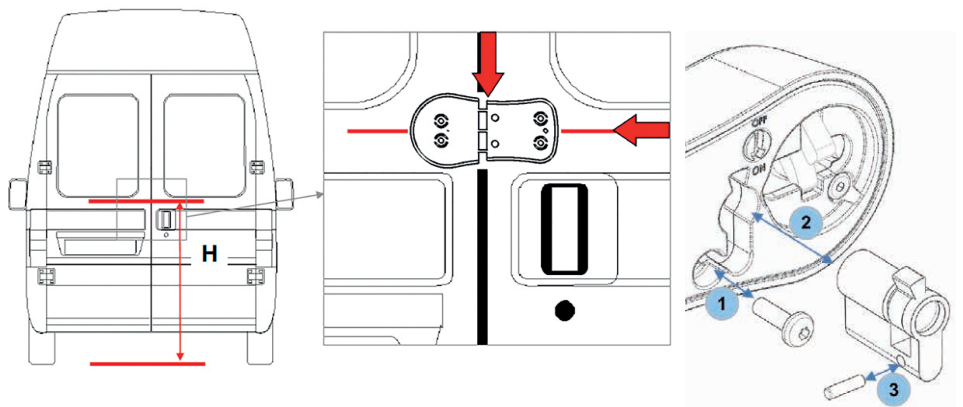

## Fixing Kit Contents

1. Lock with emergency pull cord
2. Hook plate
3. 2 keys with ID card
4. 2 x M8 screws
5. 2 x M6 screws
6. 2 x M6 screws with recessed heads
7. 4 x PlusNut-M6
8. Plastic base plate
9. Emergency release kit
10. Optional personalisation badge
11. Drill template and installation guide

# LOKHEN ORIGAMY FOLDABLE WHEEL CHOCKS

Foldable - Space-saving - Maximum installation flexibility - Resistant and durable

- Foldable, as its three sections can be folded back on themselves to a height of only 6.3 cm.
- Space-saving, as it optimises space up to 66% compared to solid wheel chocks.
- Maximum installation flexibility, it can be attached to the truck or trailer chassis, or placed in the truck's toolbox.
- Resistant and durable thanks to the use of high-grade PP and its functional design.
- National, European and international registered design.
- Patented, TÜV-certified and DIN 76051 compliant.

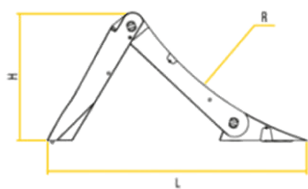
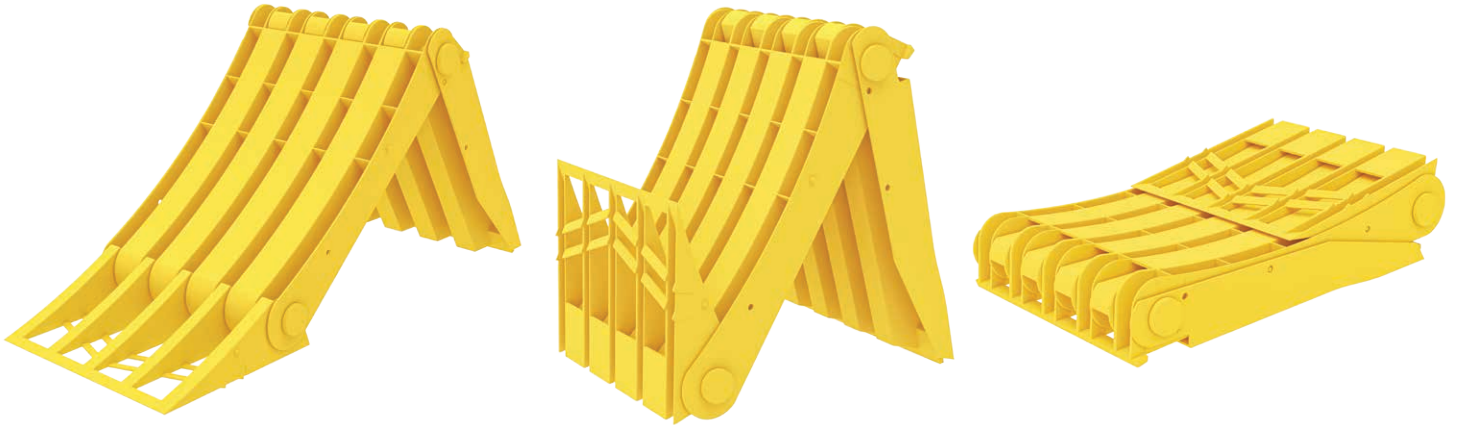

ORIGAMY 53  
Truck & Trailers

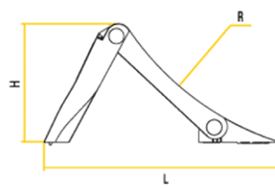
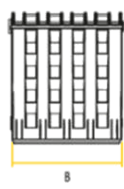

ORIGAMY 46  
Truck & Trailers  
(Commercial and Agricultural)

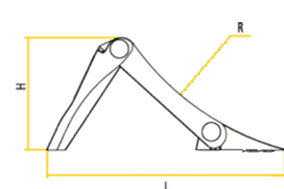

ORIGAMY 36  
LCV



Code	L mm	B mm	H mm	R mm	Weight kg
LKOR53-S	472	199	230	560	0.98
LKOR46-S	360	160	190	460	0.67
LKOR36-S	320	120	151	360	0.32